

# Plan de aprendizaje Remoto VIII

## Escuela de Lenguaje Caracola



### Segundo Nivel de Transición

Consultas al correo

Segundo Nivel de transición A Tía **Maricarmen Moreno M.** [makmoreno@hotmail.com](mailto:makmoreno@hotmail.com)

Segundo Nivel de transición B Tía **Natalia Sepúlveda L.** [natalia.sepulveda.letelier@gmail.com](mailto:natalia.sepulveda.letelier@gmail.com)

Tía **Andrea Moreno** (Fonoaudióloga) [figa.andreamoreno@gmail.com](mailto:figa.andreamoreno@gmail.com)

NOMBRE : \_\_\_\_\_

¡Te Presento una Nueva letra!

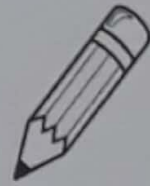
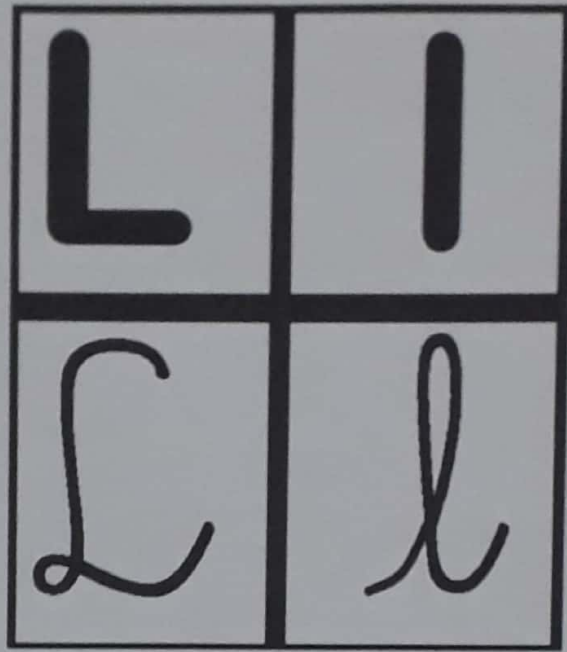

Pinta sólo los elementos que comienzan con "l"

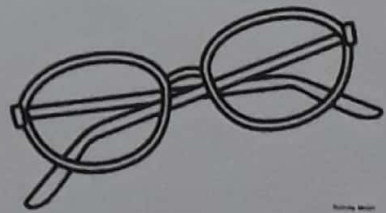
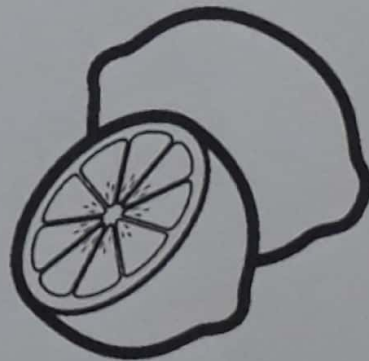
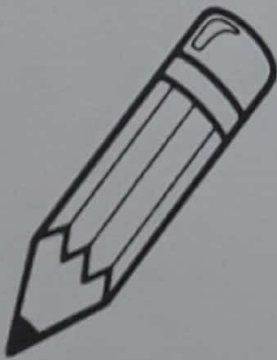

Repasa la lectura de sílabas y palabras



ACTIVIDAD: SÍLABAS

Nombre: \_\_\_\_\_

Fecha: \_\_\_\_\_

Repasa y escribe:



e →

le

a →

la

i →

li

o →

lo

u →

lu

la lo li lu le

lo lu le la li

Lola Lali lila

ala lio lee Lulú

Lee y repasa cada sílaba

www.preferecursos.com

Dibuja un elemento con cada sílaba inicial

Pinta las L de color rojo y las P de color amarillo

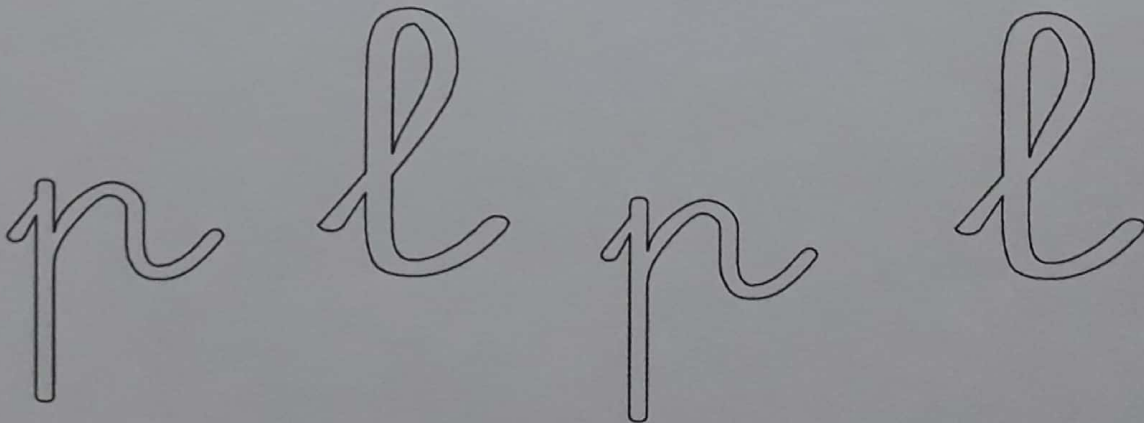
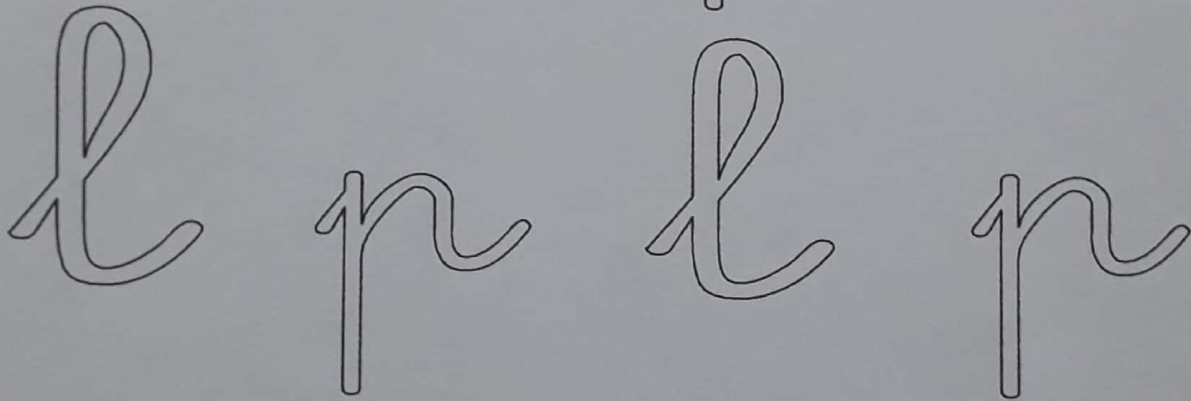
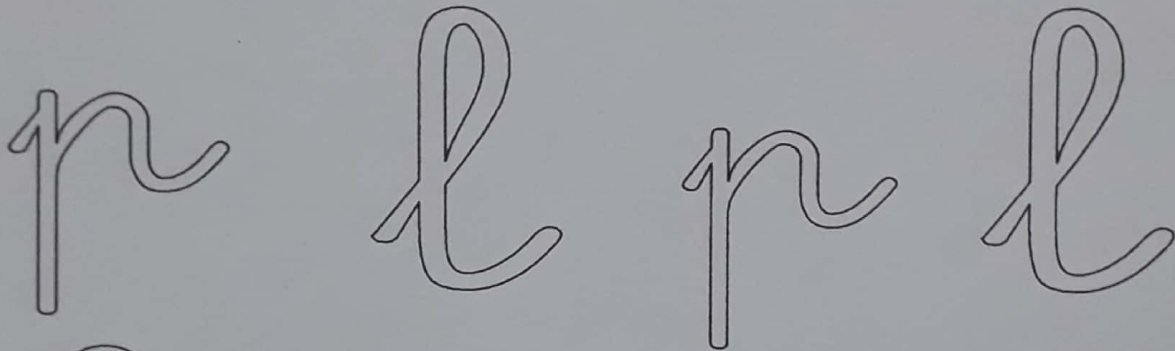
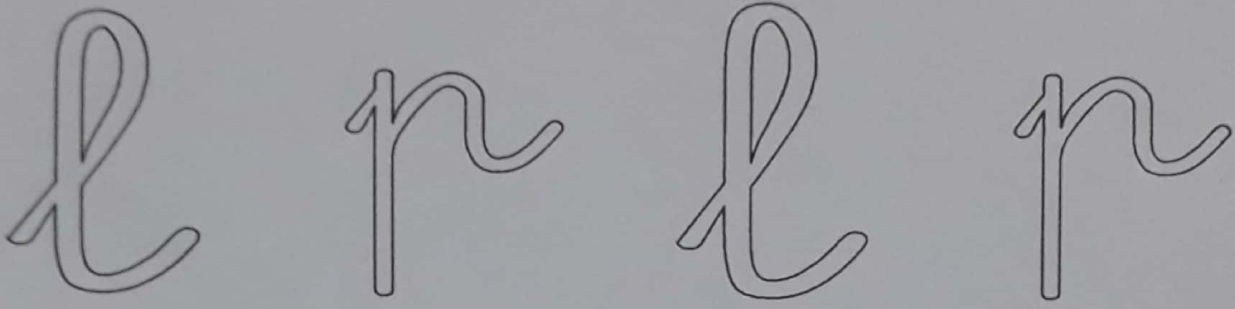



# FAMÍLIA SILÁBICA

## L

LIGUE:

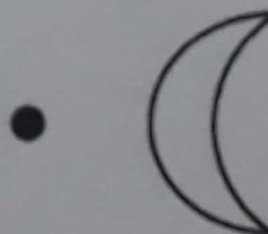

## La letra "l"

Une cada sílaba con los siguientes dibujos.

la

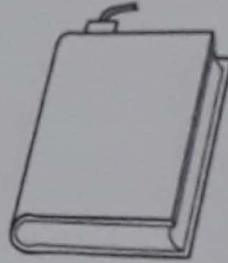

le



li



lo



lu

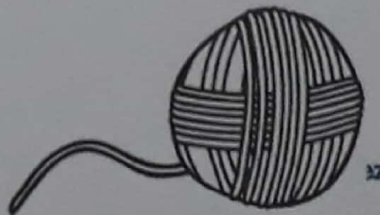

# LA LETRA "L"

1 COMPLETA:

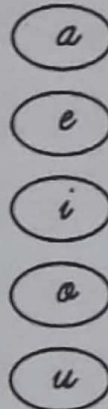
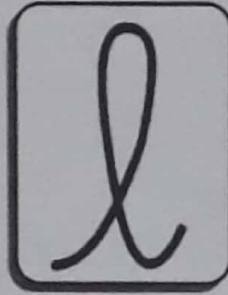

-----  
 -----  
 -----  
 -----  
 -----

2 COMPLETA las palabras con las sílabas la, le, li, lo, lu.

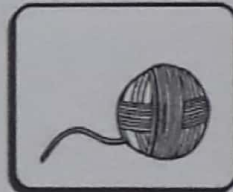
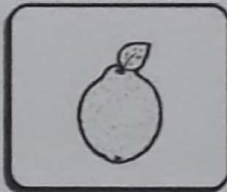

on

re

ma

na

3 ESCRIBE las palabras que podemos formar con las sílabas del cartel.



4 ESCRIBE sus nombres.

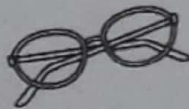
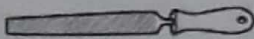

INDICADORES: Reconoce en un texto escrito palabras con "L".



Nombre \_\_\_\_\_

Las parejas. Une cada dibujo con su nombre



muela

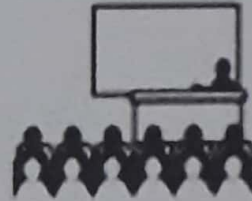

aula



ele



lila

ala



ola



óleo



mula



Nombre:



Fecha:



# L Lectura

l L  
ele

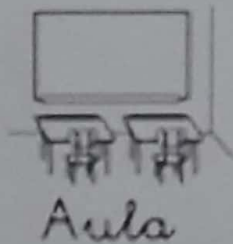
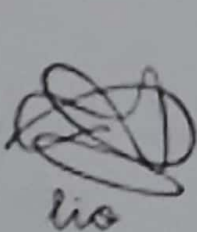

la lu li le lu  
il el al ul ol



El ala, la ola, la lila, el lio, la ele,  
el aula. Loli lee. Lola oia a Lalo.  
Ali lee la ele. Ali oia la lila.  
El aula de Loli. Lalo oia la ola

# ¡Hora de Leer!

Con ayuda de un adulto, escoge un cuento para que te lean y luego completa la siguiente ficha:



## Ficha de lectura



Mi nombre: \_\_\_\_\_

Título del libro \_\_\_\_\_

Autor: \_\_\_\_\_

Fecha inicio: \_\_\_\_\_ Fecha final: \_\_\_\_\_

Número de páginas

Tema que trata:

naturaleza

el cuerpo humano

comic

animales

flores y plantas

aventuras

adivinanzas

reyes y princesas

otros

¿Te ha gustado?



Dibujo

A large, empty rounded rectangle intended for the student to draw a picture related to the book they read.

# Estaciones del Año

- Observa y describe cada estación del año. Luego delinea y colorea cada imagen.







Busca Hojitas y pégalas en este árbol



Pinta sólo las prendas que se usan en primavera y verano

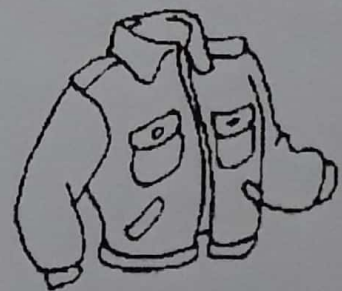
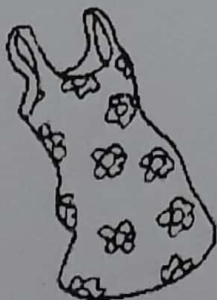
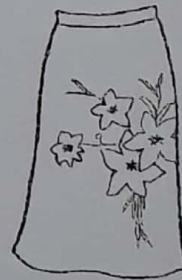
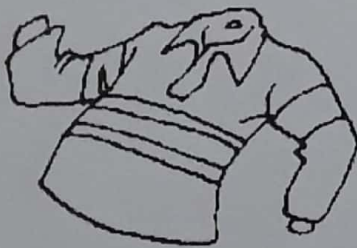
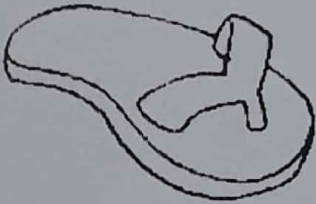
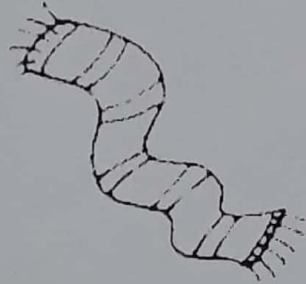
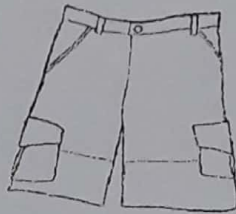

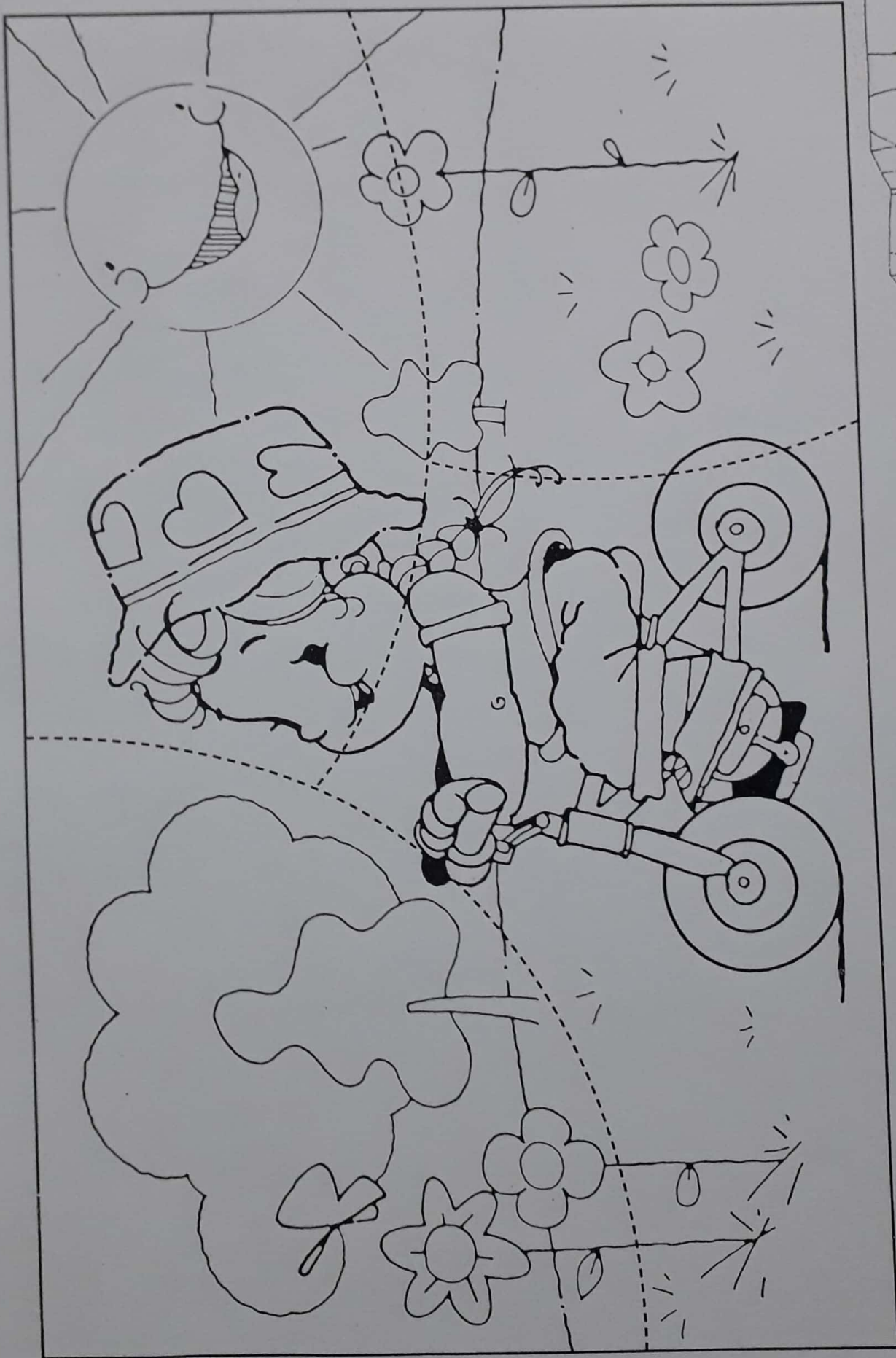

Maestra  
Jardineira

PINTA LA IMAGEN, RECORTA POR LAS LÍNEAS PUNTEADAS Y ARMA EL ROMPECABEZAS EN OTRA HOJA.



Delinea las alas y círculos de la mariposa, luego pinta y decora

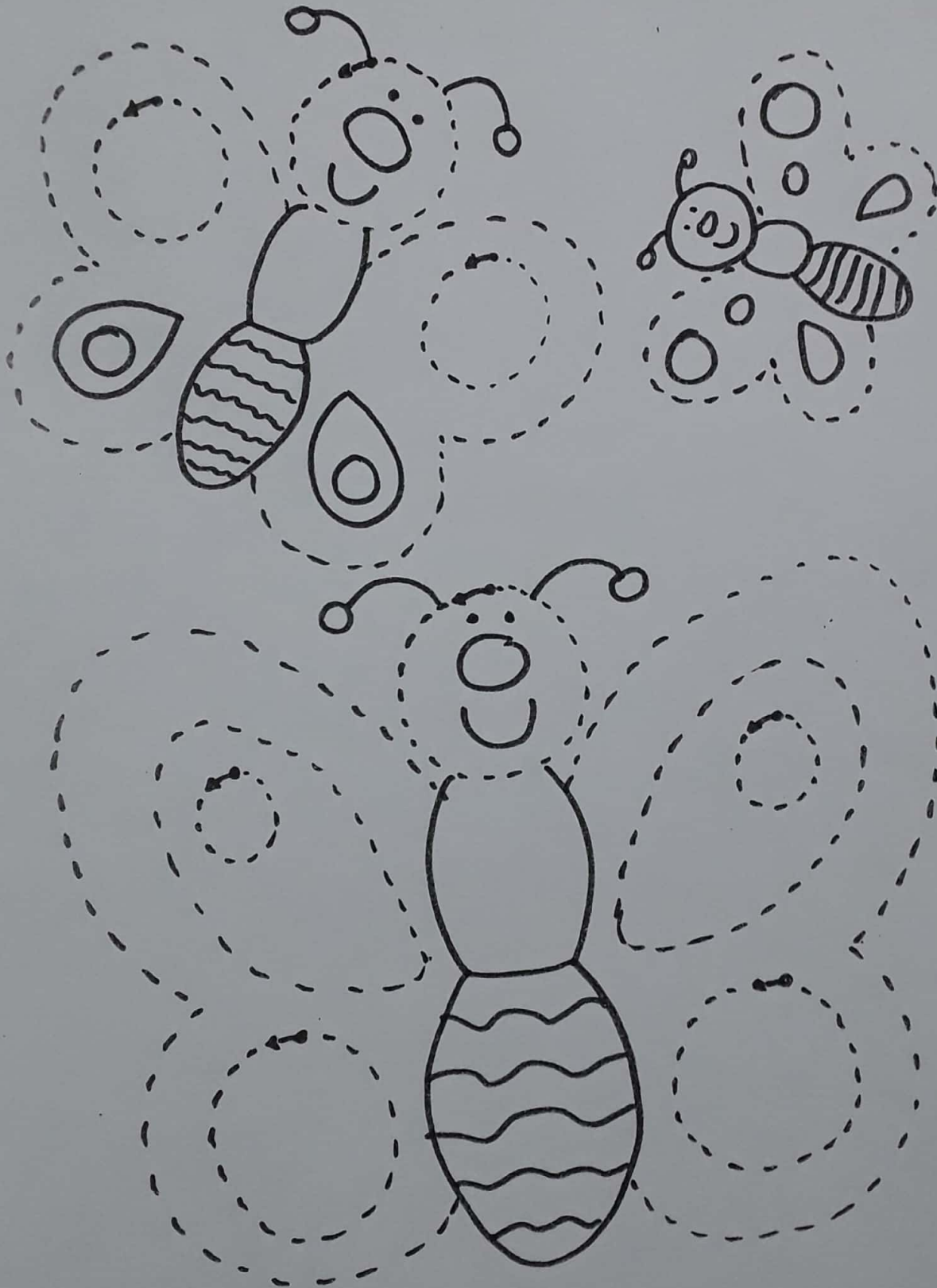



Decora cada pétalo como se indica, luego pinta el centro

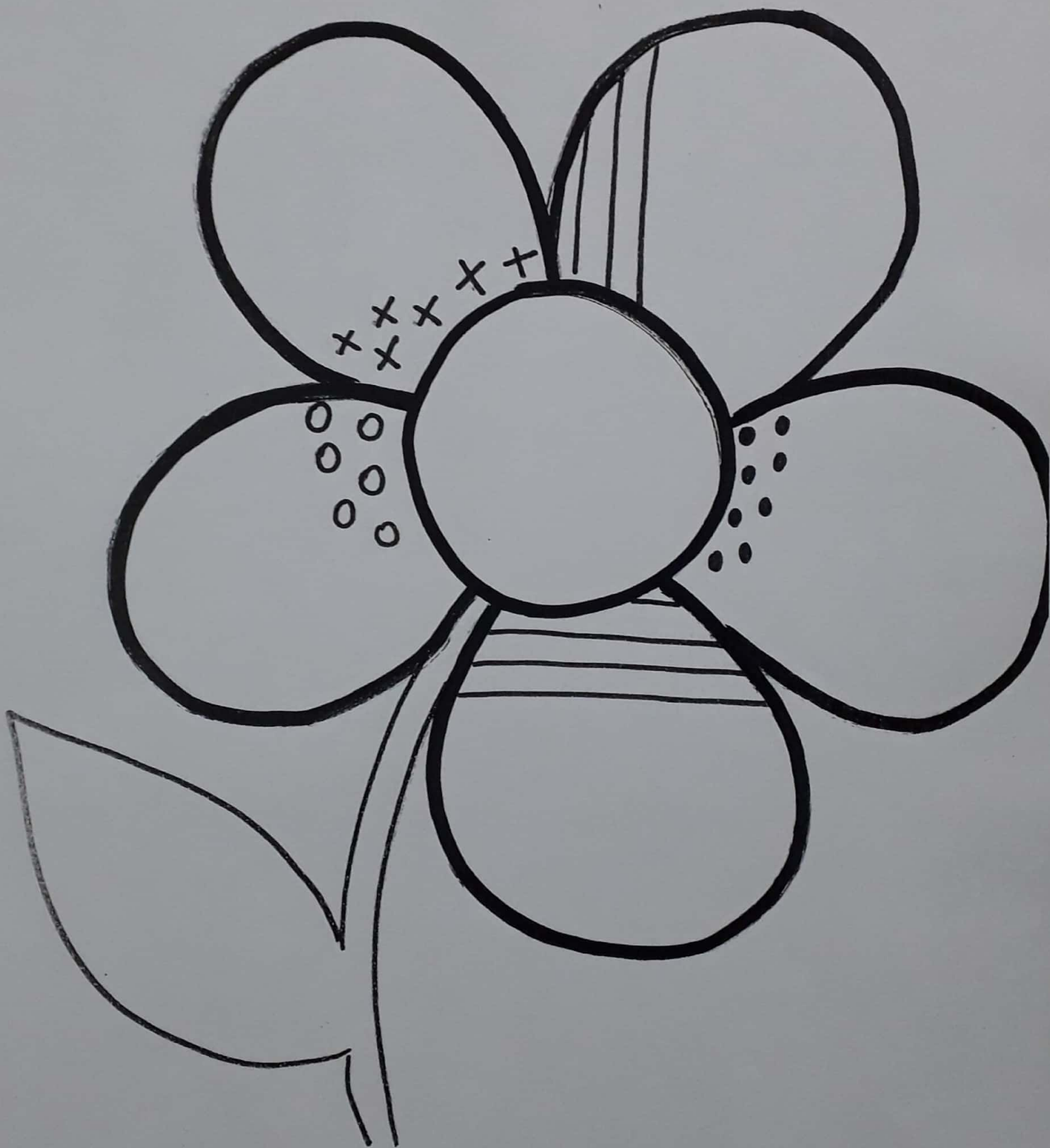

¿Recuerdas este número? Rellénalo libremente

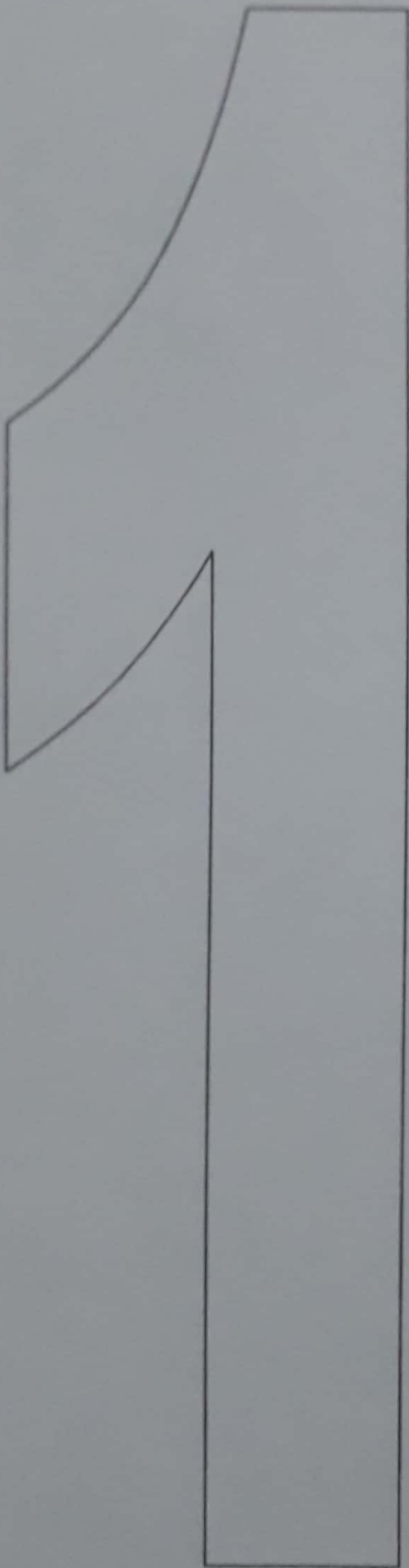



Repasa el trazo

Pega etiquetas según el número

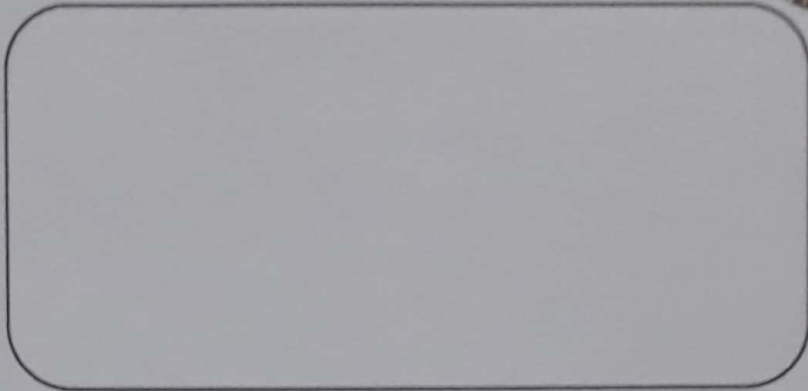
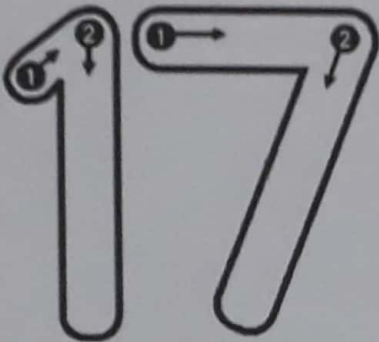

Encierra todos los números DIECISIETE

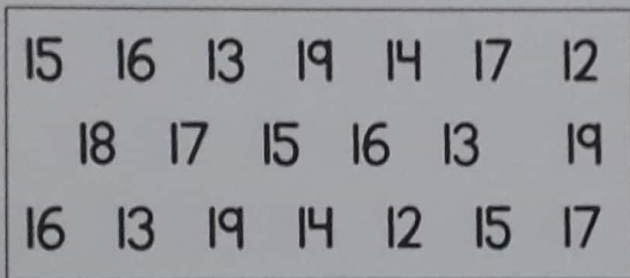

Resta uno y suma uno

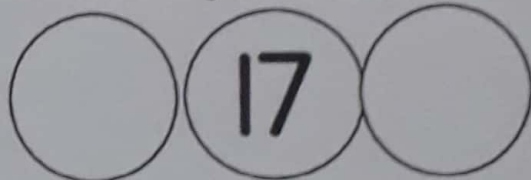

antes

después

Colorea los pétalos según el número

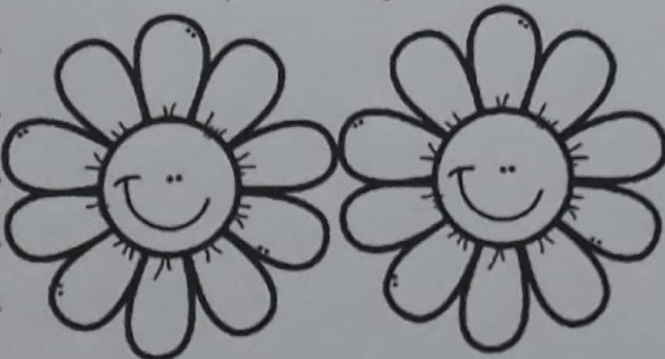

Circula el número de estrellas según corresponde al número

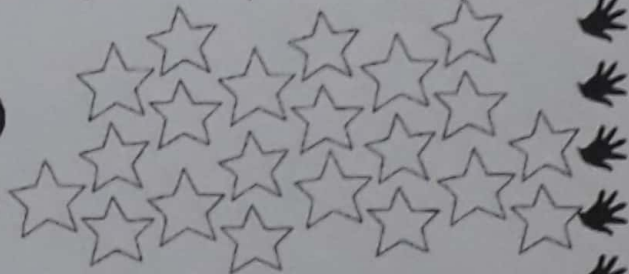

Repasa la escritura

Diecisiete

diecisiete

diecisiete

Diseñó y elaboró Diana Monterrubio

Rellena con puntitos este número 18



18 18 18 18 18 18 18 18 18 18

dieciocho dieciocho dieciocho dieciocho

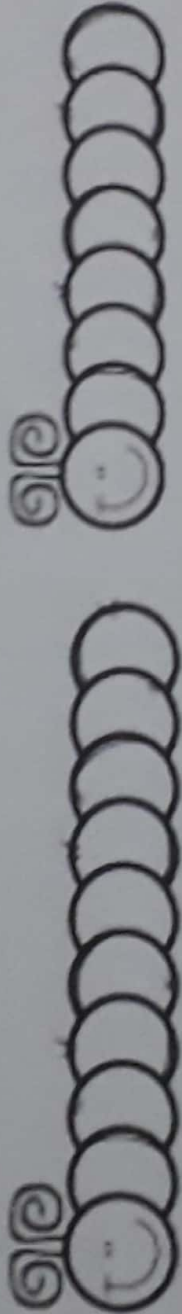

18

$10 + 8 = \square$

$6 + 12 = \square$

$9 + 9 = \square$

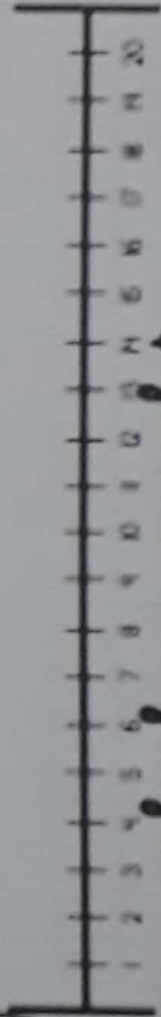

Traza, calcula y completa

Escuela Primaria  
Luisa C. de...

Completa los números, luego encierra los 17 y pinta los 18

17 18 17 18

18 17 18 17

17 18 17 18

18 17 18 17

17 18 17 18



1  
2  
3  
4  
5  
6  
7  
8  
9  
10  
11  
12  
13  
14  
15  
16  
17  
18  
19  
20  
21  
22  
23  
24  
25  
26  
27  
28  
29  
30

- RECORRE VARIAS VECES LOS NÚMEROS CON TU DEDO ÍNDICE EN LA DIRECCIÓN INDICADA.
- COLORÉALOS COMO MÁS TE GUSTE.
- CUENTA Y COLOREA LOS CARACOLES Y LAS MASITAS.
- DELINEA Y COMPLETA CADA RENGLÓN.

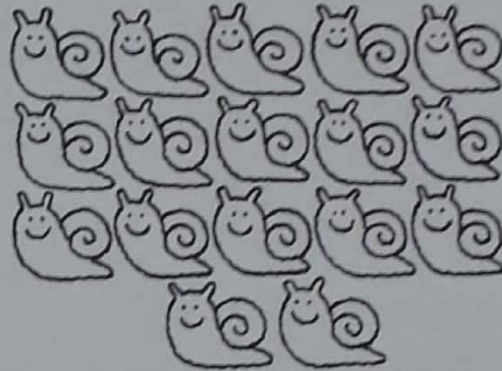
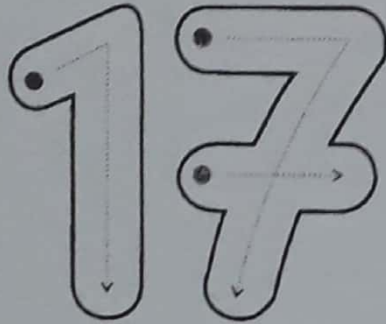

DIECISIETE

17 - 17 - 17 - 17 - 17 - 17 - 17 - 17 -

17

17

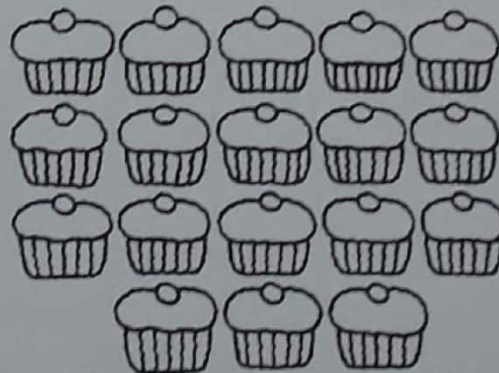
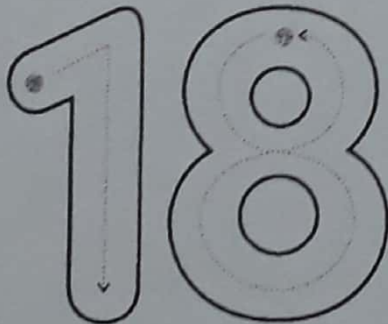

DIECIOCHO

18 - 18 - 18 - 18 - 18 - 18 - 18 - 18 -

18

18



# COMPLETA LA SERIE Y CÓPIALA DEBAJO.

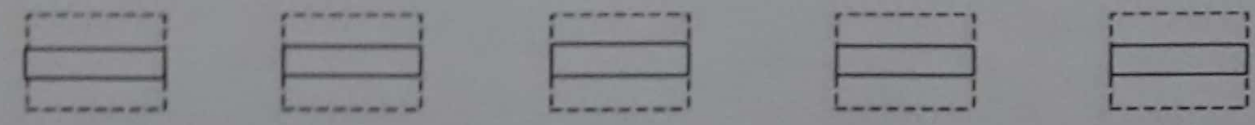
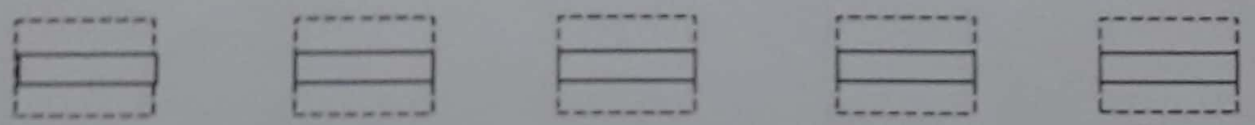
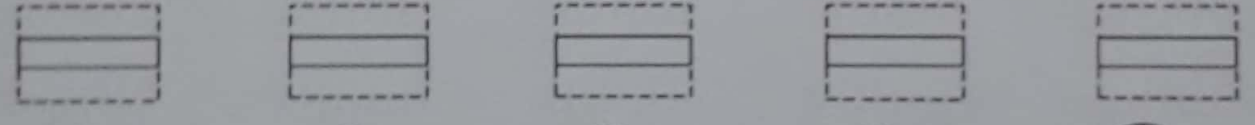
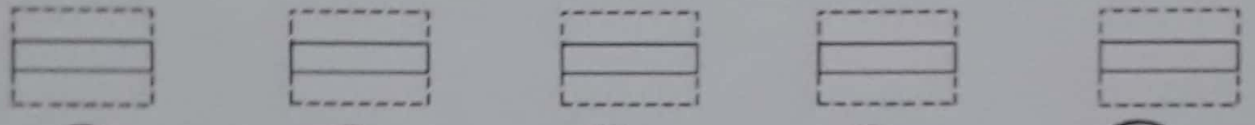

► Completa la serie descendente

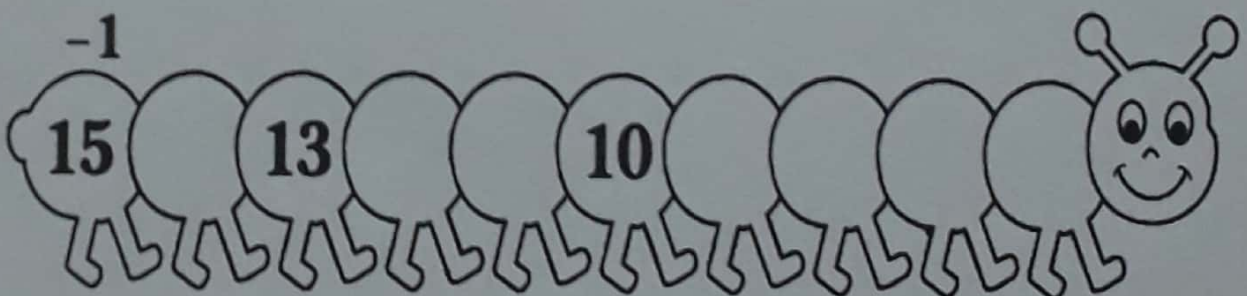
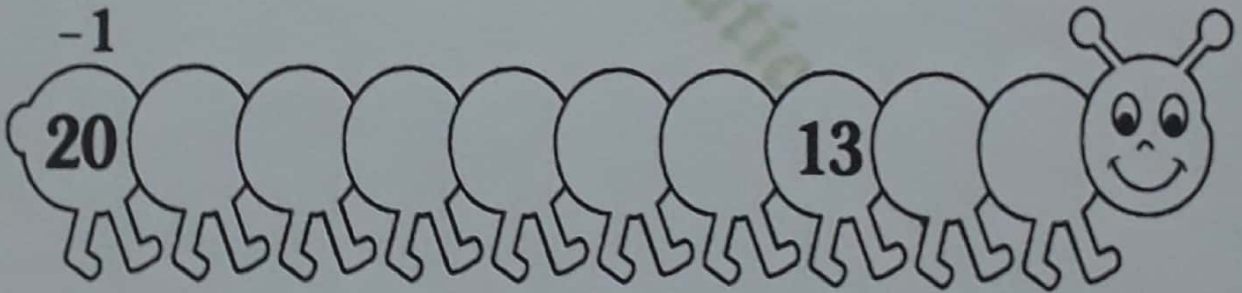
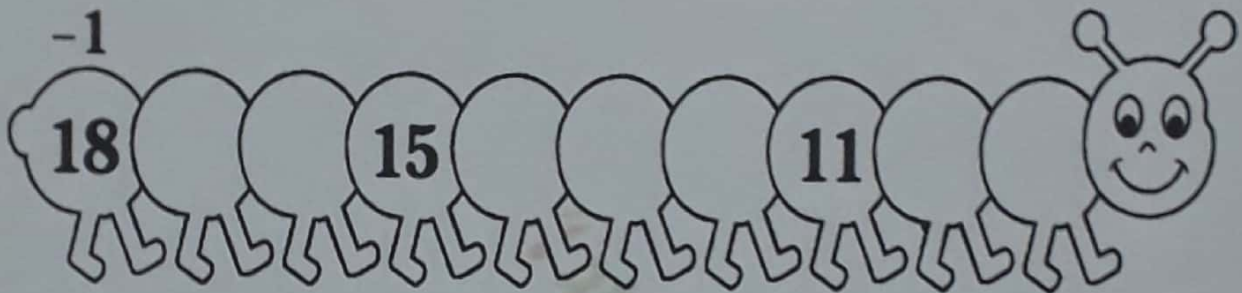
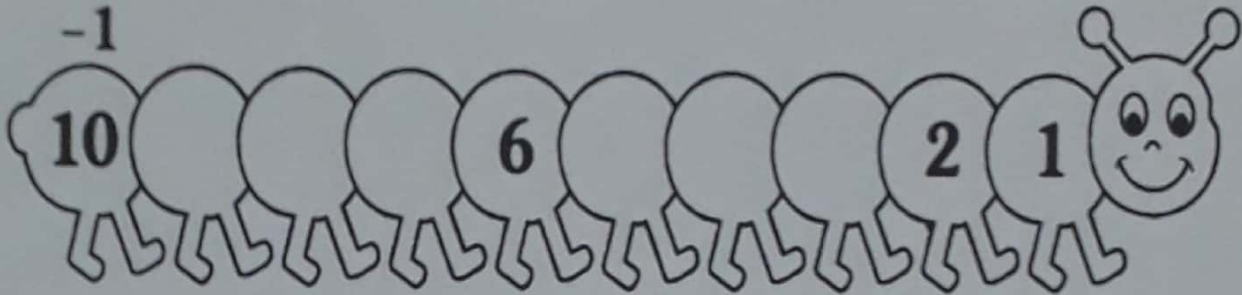

## SUCESIÓN NUMÉRICA ASCENDENTE Y DESCENDENTE

A.E. Sucesión numérica, ascendente y descendente de 1 en 1, a partir de un número dado.

El príncipe debe rescatar a la princesa, ayúdalo a llegar al castillo completando la numeración **ascendente**, luego bajarán hasta su caballo siguiendo la numeración **descendente**.

10

9

8

6

5

4

2

1

Contesta:

¿De cuánto en cuánto avanzó el príncipe para llegar al castillo?

\_\_\_\_\_



# La Casa y sus Dependencias

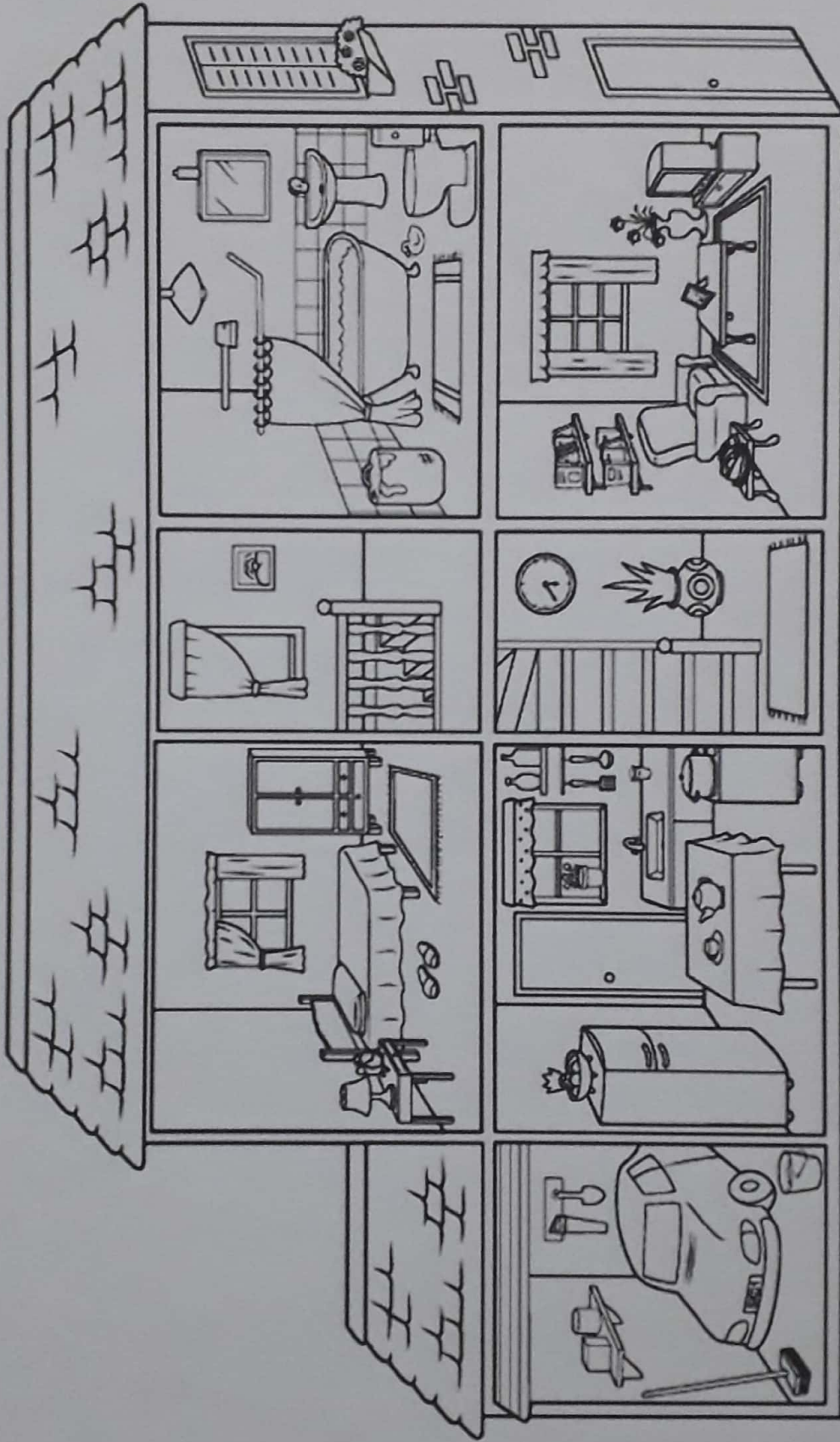

Pinta el lugar donde dormirías.

Dibuja un niño en el Baño

Encierra el lugar donde se cocina



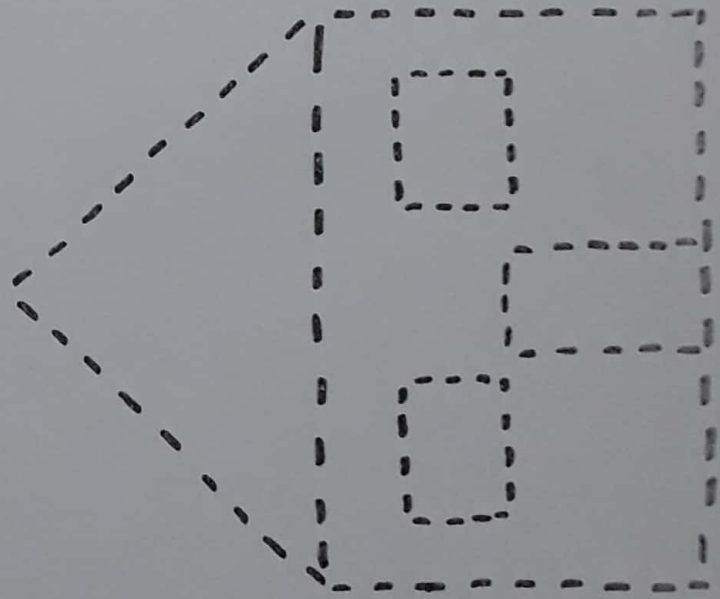
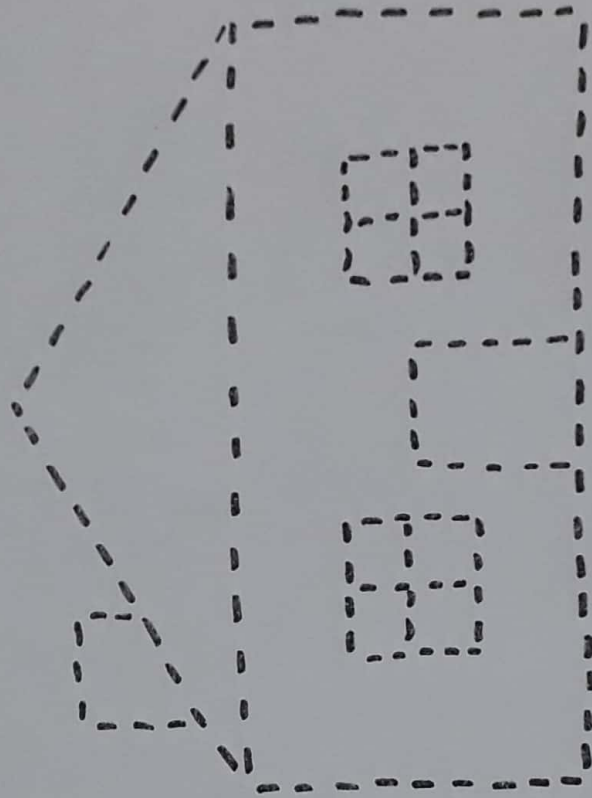

Completa cada casa, luego pinta rojo el techo, azul las ventanas, amarillo los muros y verde la puerta

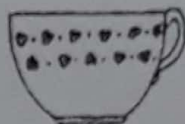
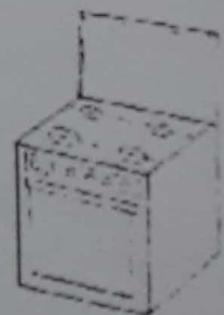
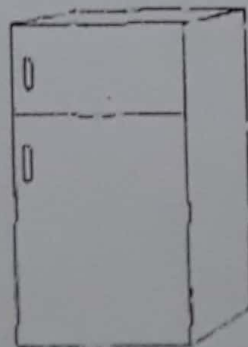
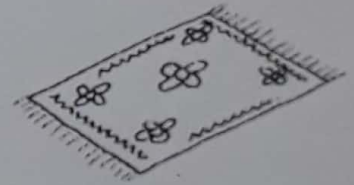
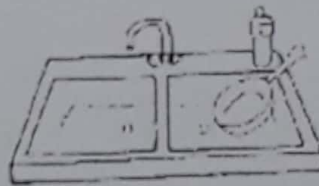
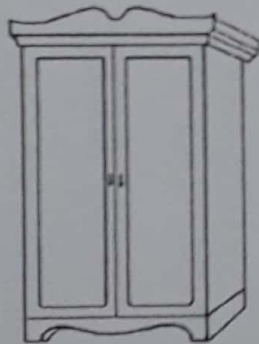
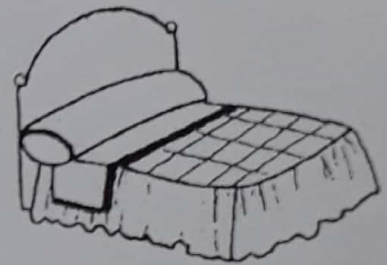
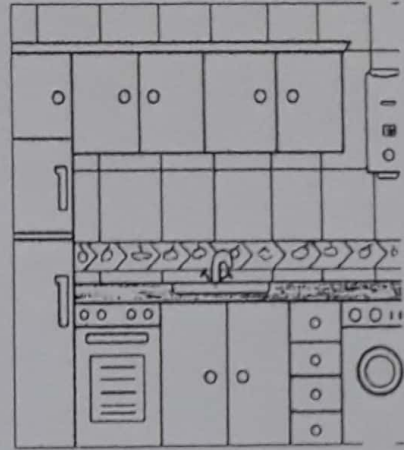
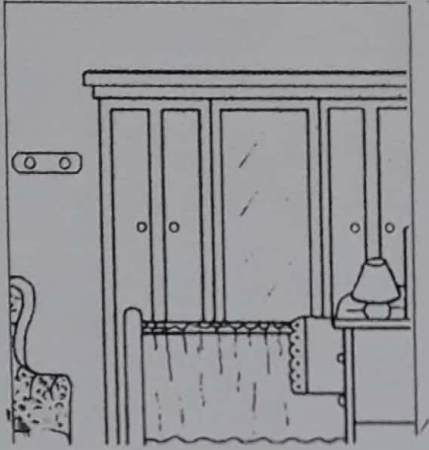

Encierra de color rojo los elementos que hay en el dormitorio y de color azul, los que hay en la cocina

Une cada parte de la casa con el elemento que corresponda

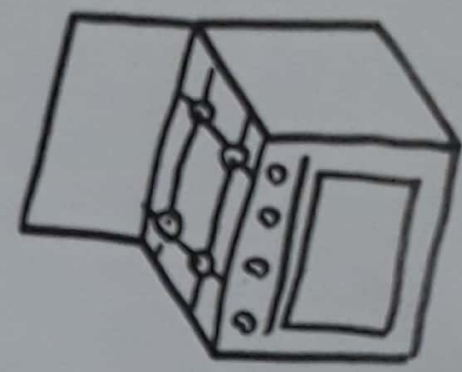
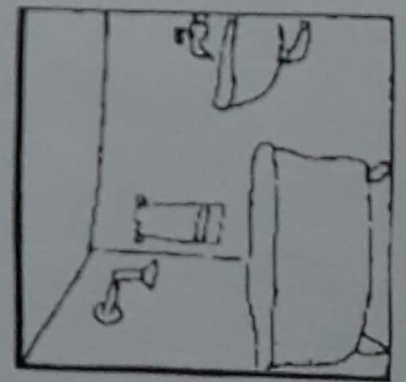
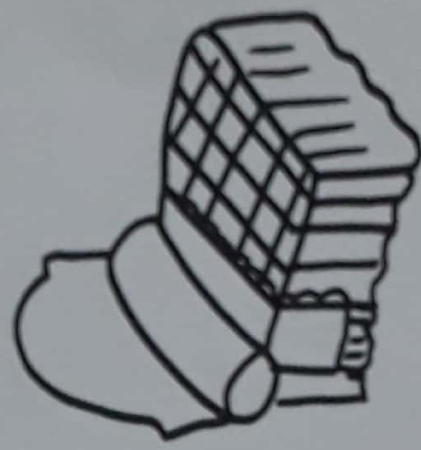
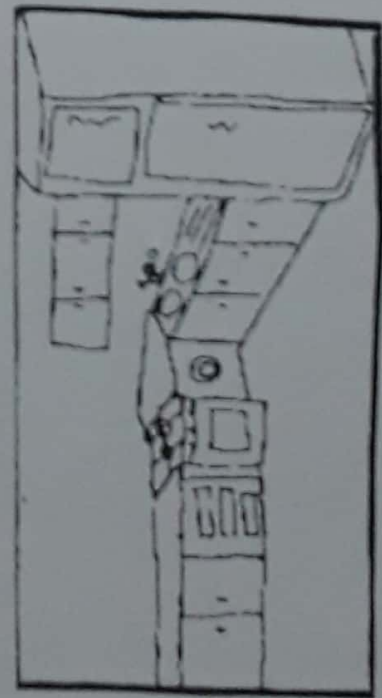
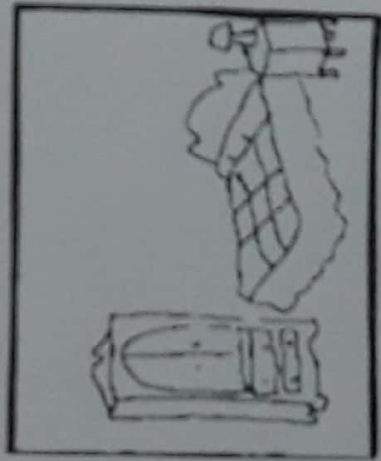

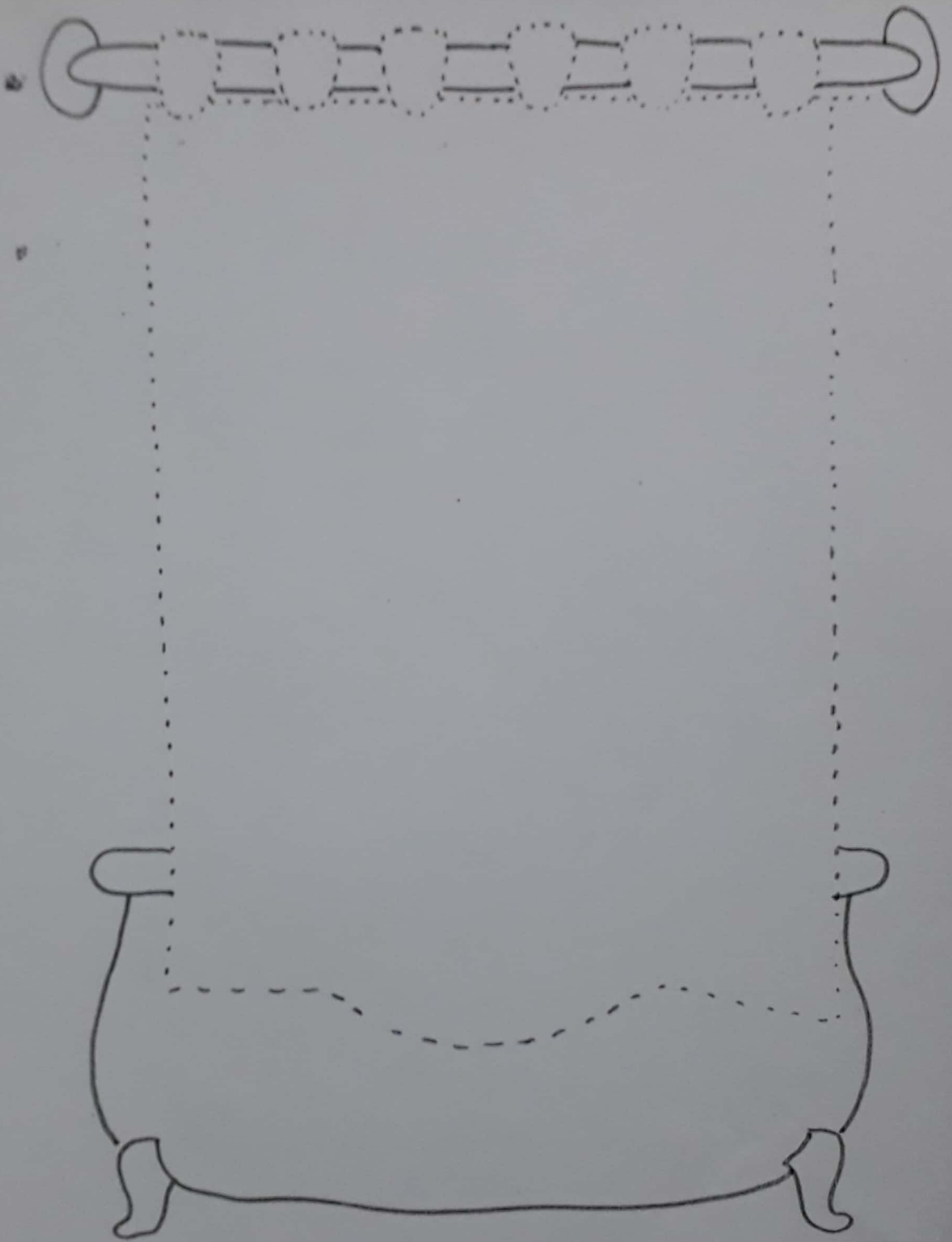

Marca la Cortina de Baño y luego rellénala



Completa esta casa con los elementos faltantes

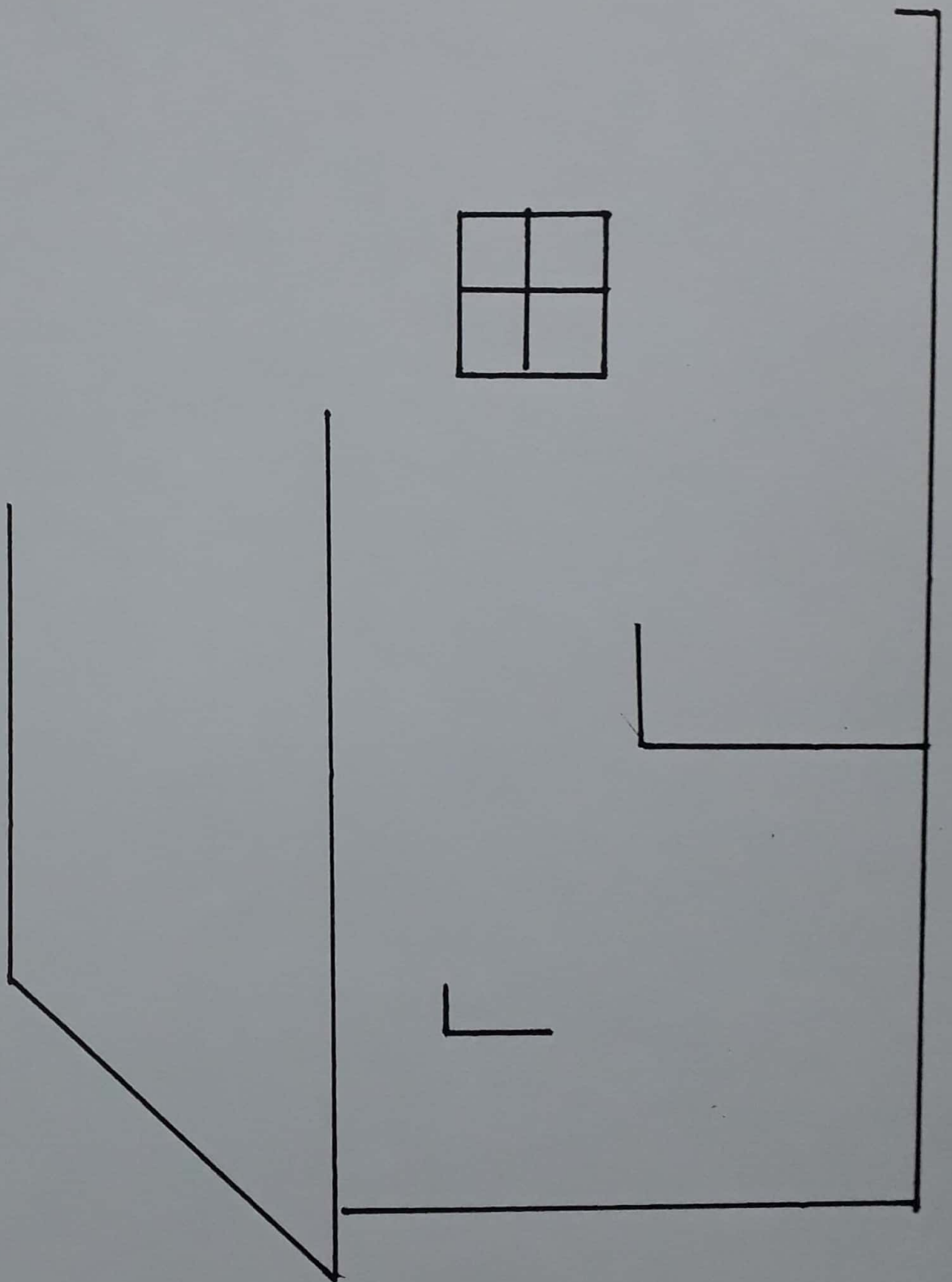

# Guía de trabajo fonoaudiológico en casa

## Nivel Kinder

### Actividades semana 18

#### 1. Objetivo de aprendizaje: Los oficios

### *Conociendo los Oficios*

Los oficios son trabajos que realizan las personas adultas. Para poder realizar estos trabajos, no necesitan estudiar una larga carrera en la universidad. Algunos oficios necesitan preparación, como es el caso de los carabineros y cocineros. Observa atentamente las imágenes y une cada oficio con el elemento que utilizan para realizar su trabajo. Luego colorea.

carnicero

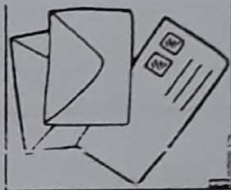

bombero



cartero

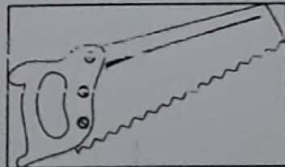
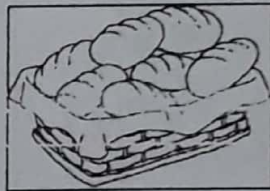

panadero

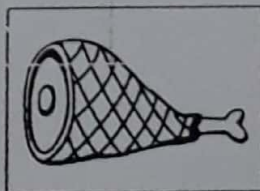

carpintero

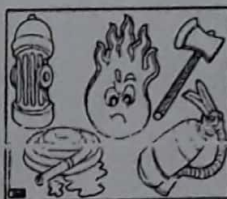

2. Objetivo de aprendizaje: Los oficios

Observa atentamente y une cada oficio con su lugar de trabajo. Luego colorea.

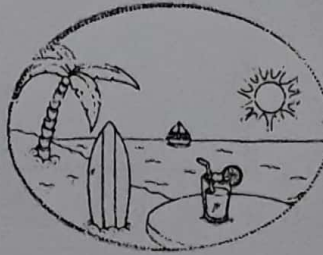
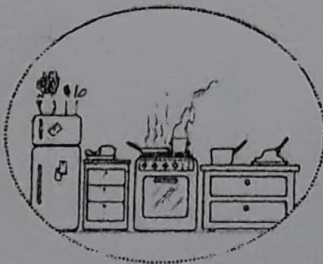
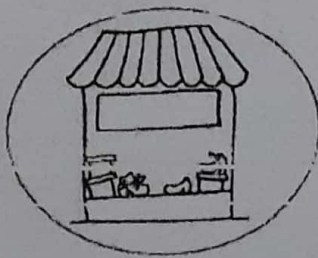
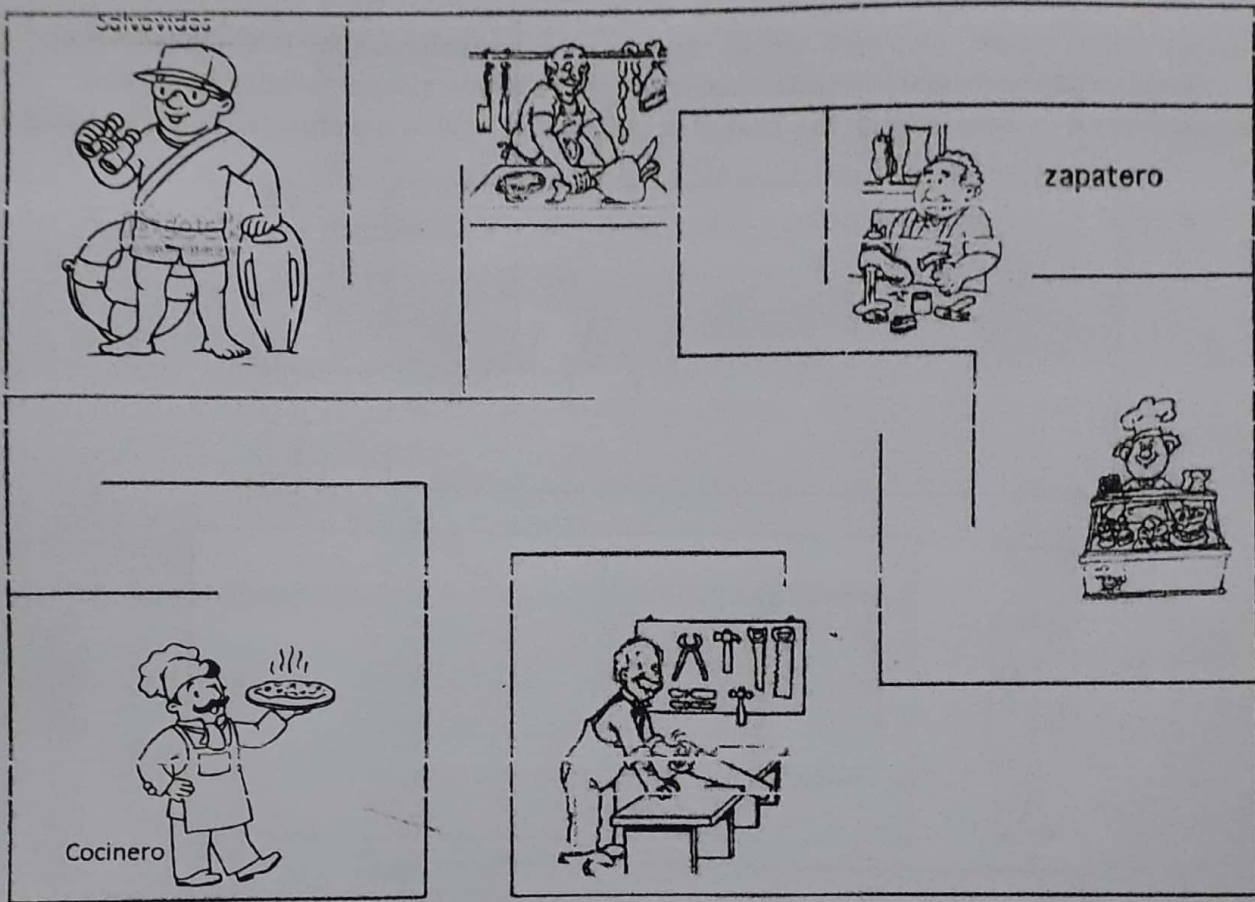

## Actividades semana 19

1. Objetivo de aprendizaje: Las profesiones

### Conociendo las profesiones.

Las profesiones son trabajos que realizan las personas adultas. Para poder realizar estos trabajos, se necesita estudiar una larga carrera en la universidad. Observa atentamente las imágenes y completa con el elemento que utilizan para realizar su trabajo. Los recortes están en la página siguiente

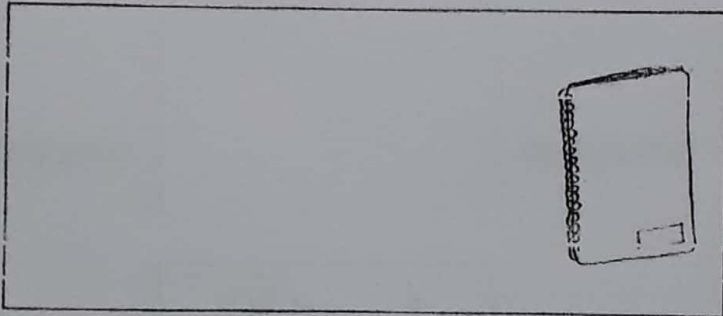
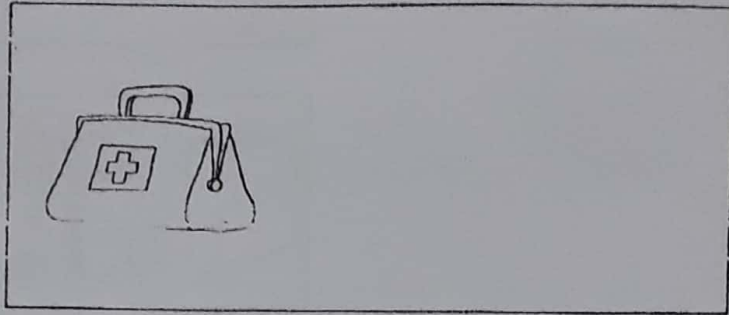

Astronauta

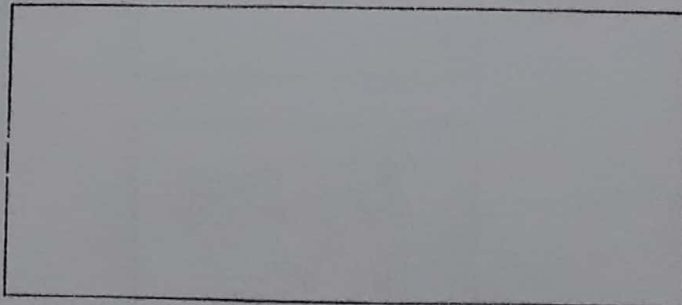
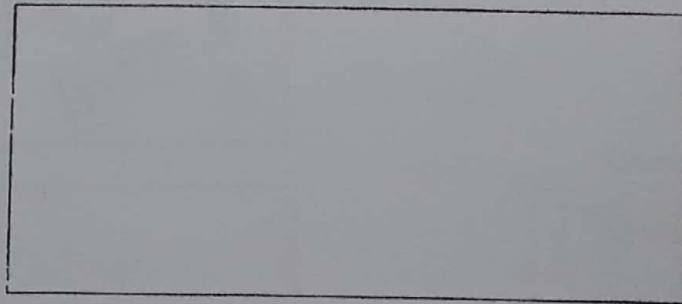



2. Objetivo de aprendizaje: Las profesiones

Usted lee. El/la niño/a comenta y aprende. Deben completar el recuadro en blanco con la profesión que falta, utilizando los recortes que aparecen en la siguiente hoja. Colorea.

Hola amiguito/a soy la



trabajo en una

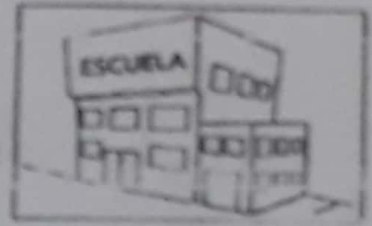

y para trabajar utilizo

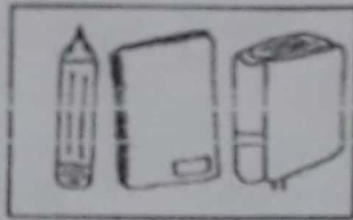

Hola amiguito/a soy la

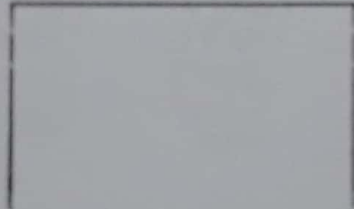

trabajo en el

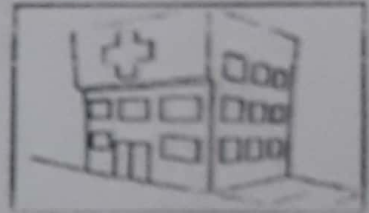

curo a los enfermos con

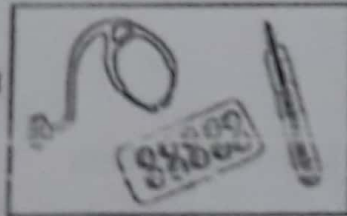

Hola amiguito/a soy el

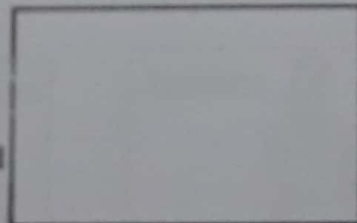

trabajo en la



curo a los

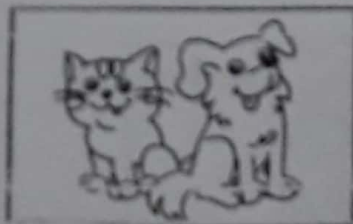

# Recortes

## Actividad n°1 profesiones:

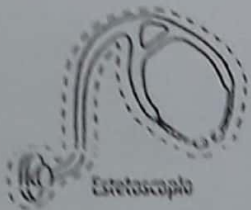
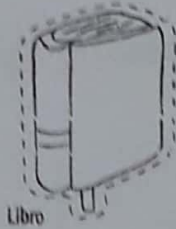
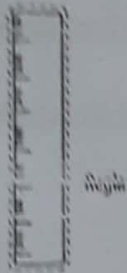

## Actividad n°2 profesiones:

(¡ojo! Hay un distractor)

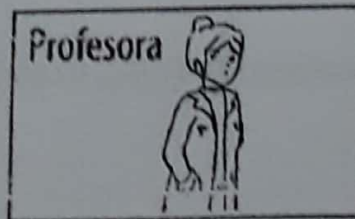
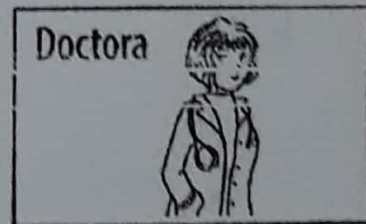
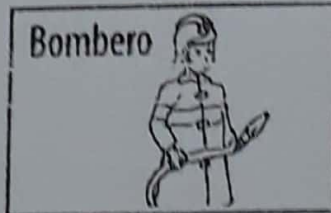
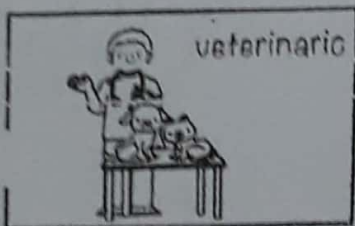

## Actividades semana 20

1. Objetivo de aprendizaje: Útiles escolares.



### Conociendo útiles escolares

Observar y comentar. Luego colorea solo útiles escolares.

La profesora de José le pidió que guardaran en la mochila solo útiles escolares.

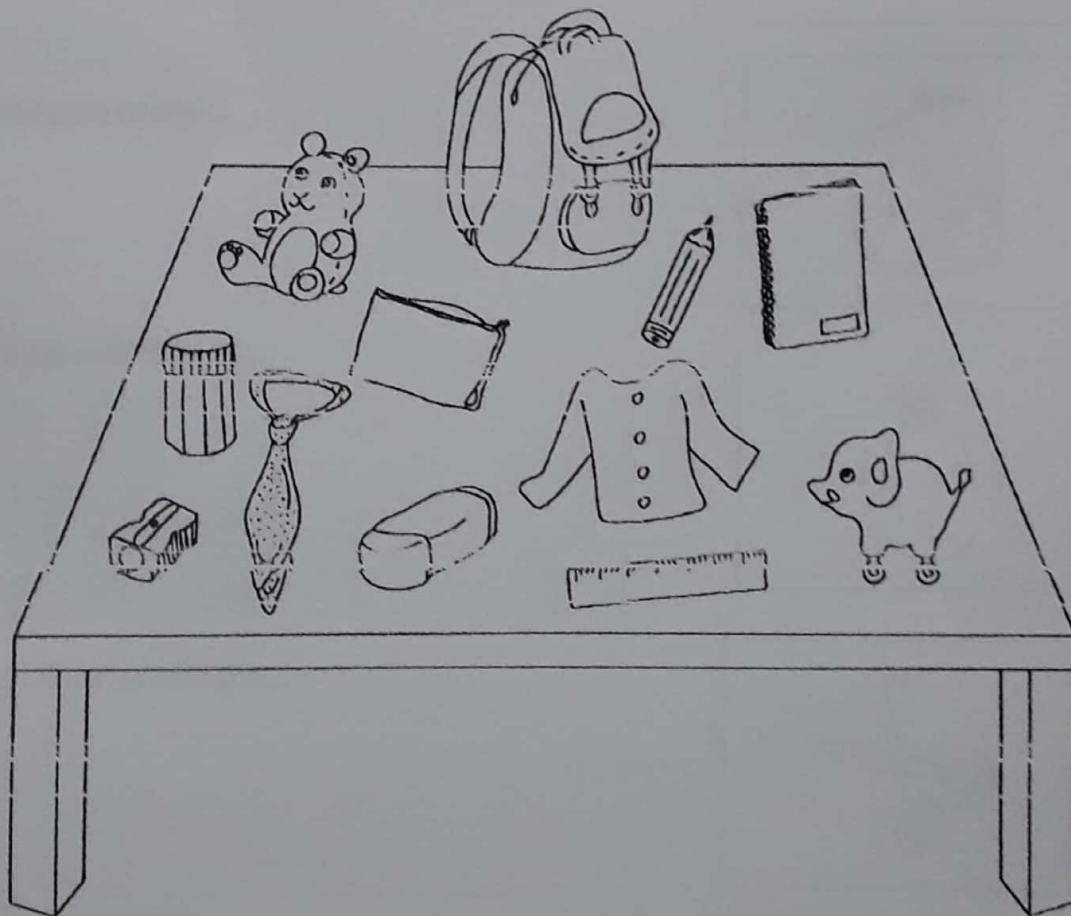

-Objetivo: Clasificar elementos de la categoría semántica útiles escolares.

L / ED / NL

2. Objetivo de aprendizaje: Útiles escolares.

Usted lee, el niño/a escucha, observa las imágenes, completa y une según corresponda.

Para pegar uso...

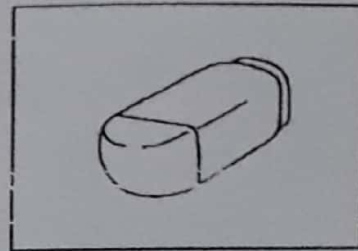

María usa para borrar la...



José usa para recortar las...



Isidora pinta un cuadro con...

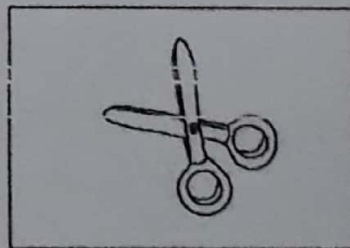

Para guardar los útiles escolares uso la...

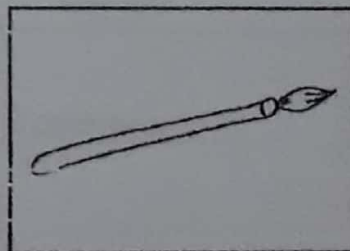

•Objetivo: Completar oraciones.

L / ED / NL





Actividades semana 21

1. Objetivo de aprendizaje: Pronombres personales.

# Conociendo los pronombres

Observa, escucha y comenta. Luego responde.

Usamos "ELLA" cuando es mujer  y "ÉL" cuando es hombre 

Él come frutas.  
¿Quién come frutas?  
¿Él o ella? .....



Ella come su comida.  
¿Quién come su comida?  
¿Él o ella? .....



Dibuja según corresponda:

Ella toma jugo.

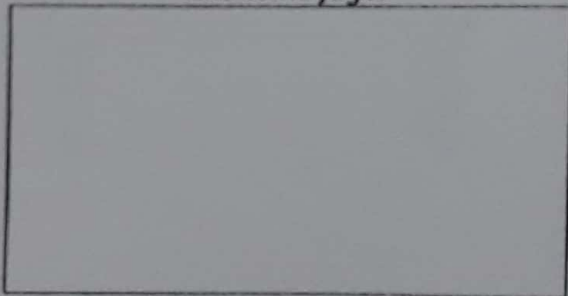

Él come pan.

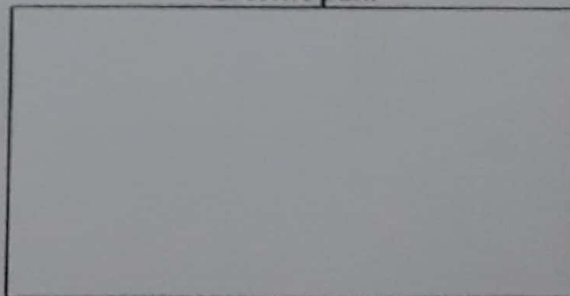

Objetivo: Identificar y utilizar pronombres personales.

L / ED / NL

2. Objetivo de aprendizaje: pronombres personales

# Conociendo pronombres y verbos

Observa y comenta. Usted lee y el niño/a une el pronombre al verbo que corresponda.

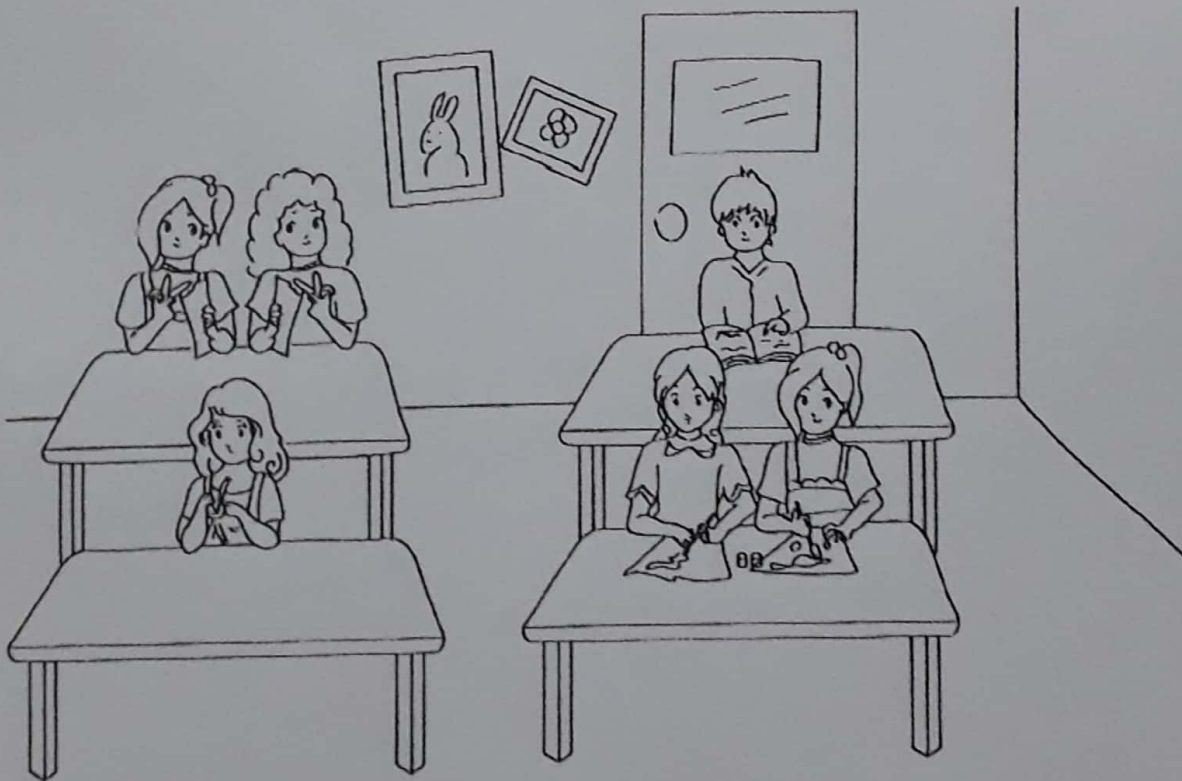

Objetivo: Identificar pronombres en singular y plural.

L / ED / NL

Estimados Apoderados:

Junto con saludar y esperando que se encuentren muy bien junto a sus familias.

Les envío set de actividades del taller de inglés, correspondiente al mes de septiembre para desarrollar en casa. Adjunto 4 link que pueden ver junto a sus hijos(as) en cada actividad.

- Siempre comenzar con la canción "Hello" ya que indica el inicio de cada taller (es por eso que repito este link en cada entrega)

<https://www.youtube.com/watch?v=gghDRJVxFxU>

- Para realizar las 5 actividades pueden ver los videos de los siguientes links

<https://www.youtube.com/watch?v=faC03JNC0wU>

<https://www.youtube.com/watch?v=B2S6g3OigmQ>

<https://www.youtube.com/watch?v=Ut-HbauKzDw>

UNIT 6: THE MEANS OF TRANSPORT

ACTIVITY 1

NAME: \_\_\_\_\_ DATE: \_\_\_\_\_

- LOOK, REPEAT AND COLOR THE CAR (MIRA, REPITE Y COLOREA EL AUTO)

**CAR**

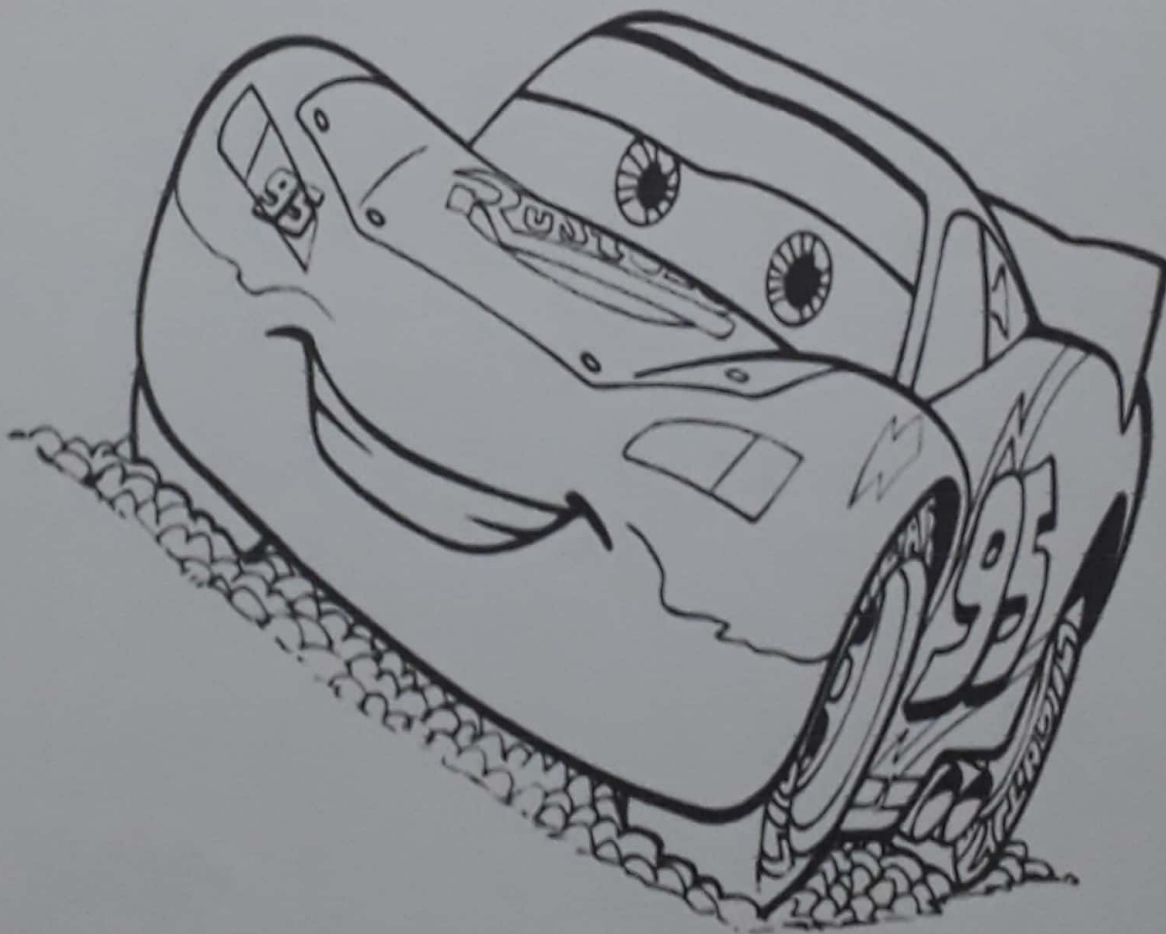



UNIT 6: THE MEANS OF TRANSPORT

ACTIVITY 2

**NAME:** \_\_\_\_\_ **DATE:** \_\_\_\_\_

- *Color the Motorcycle and draw the truck load (Colorea la motocicleta y dibuja la carga del Camión)*

**MOTORCYCLE**

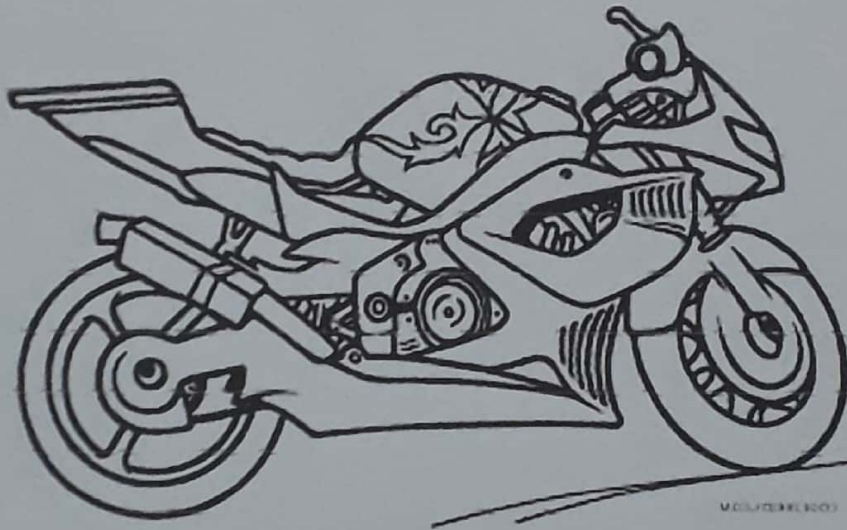

**TRUCK**

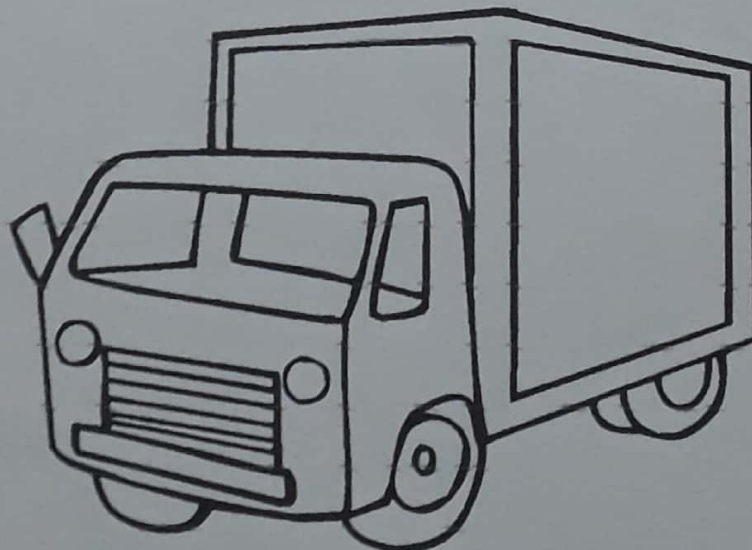

UNIT 6: THE MEANS OF TRANSPORT

ACTIVITY 3

NAME: \_\_\_\_\_

DATE: \_\_\_\_\_

- Color the passengers of the bus and the cars of the train (Colorea los pasajeros del bus y los carros del tren)

**BUS**



**TRAIN**



UNIT 6: THE MEANS OF TRANSPORT

ACTIVITY 4

NAME: \_\_\_\_\_

DATE: \_\_\_\_\_

- Draw a boy on top of the bike and then color (Dibuja un niño arriba de la bicicleta y luego colorea)

**BIKE**



**UNIT 6: THE MEANS OF TRANSPORT**

**ACTIVITY 5**

**NAME:** \_\_\_\_\_

**DATE:** \_\_\_\_\_

- **Color the means of ground transportation (Colorea los Medios de Transporte Terrestres)**

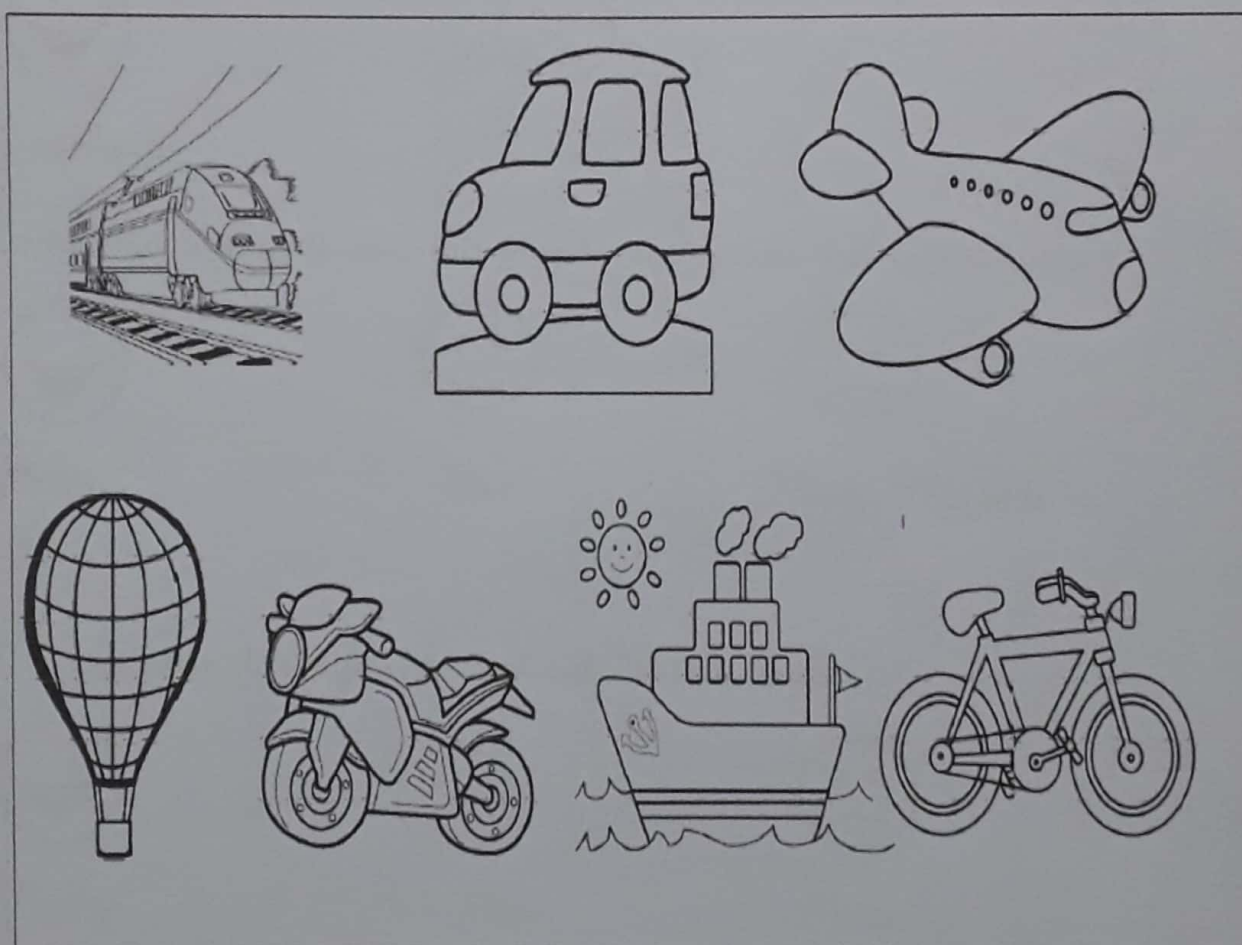



## Autoevaluación para niños y niñas

Nombre: \_\_\_\_\_

Fecha: \_\_\_\_\_



Colorea la cara que refleje mejor lo que sientes:

- ¿Cómo me sentí realizando las actividades?



Muy contento



Contento



Triste

- ¿Cómo me comporté con mis papás realizando las actividades?



Muy Bien



Bien



Puedo Mejorar

- ¿Me gustaron las diferentes actividades que realice?



Mucho



Un Poco



Nada

- ¿Qué actividad fue la que más te gusto realizar? (El adulto a cargo escribe la respuesta).

---

---

---

- ¿Qué actividad fue lo menos te gusto realizar? (El adulto a cargo escribe la respuesta).

---

---

---

- ¿Qué actividad fue la más fácil de realizar? (El adulto a cargo escribe la respuesta).

---

---

---

- ¿Qué actividad fue la más difícil de realizar? (El adulto a cargo escribe la respuesta).

---

---

---