

Plan de aprendizaje Remoto IX

Escuela de Lenguaje Caracola



Nivel Medio Mayor

Consultas al correo

Tía Amariliz Muñoz I. Munozamariliz@gmail.com

Tía Andrea Moreno (Fonoaudióloga) flga.andreamoreno@gmail.com

NOMBRE : _____

Los medios de transporte

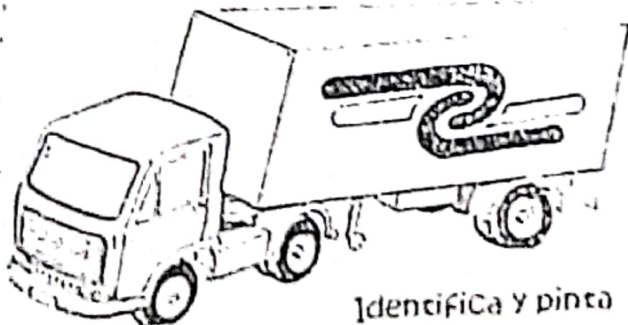
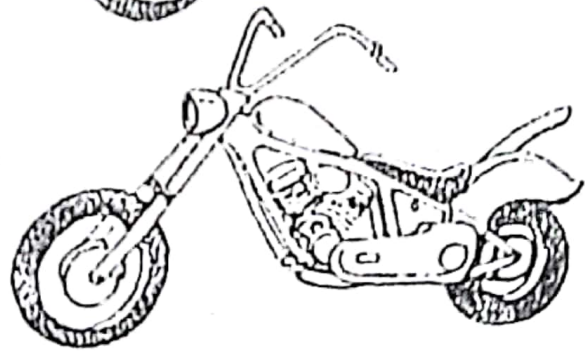
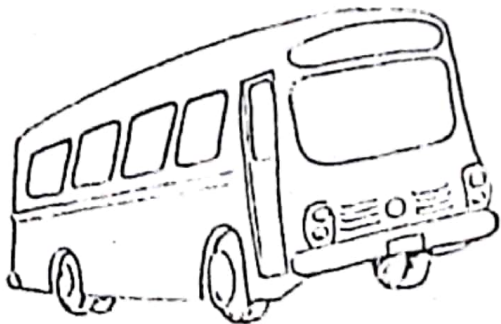
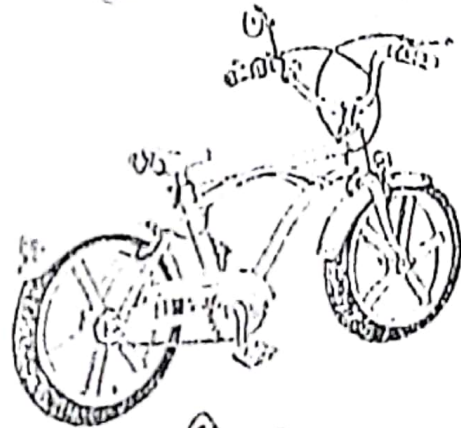
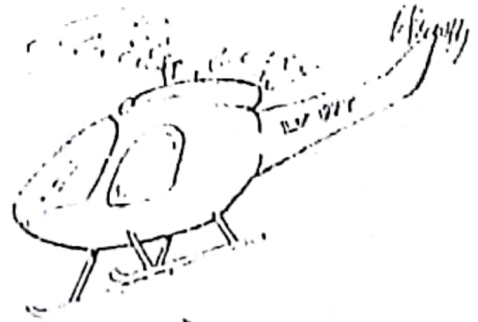
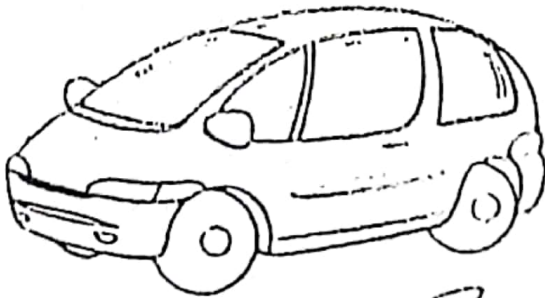

Identifica y pinta

Los medios de transportes son muy importantes, ya que ellos nos permiten viajar y trasladar elementos de un lugar a otro, cortas y largas distancias.

Entre ellos encontramos tres tipos de medios de transportes los que se desplazan por aire, tierra y agua

Colorea los medios de transporte.

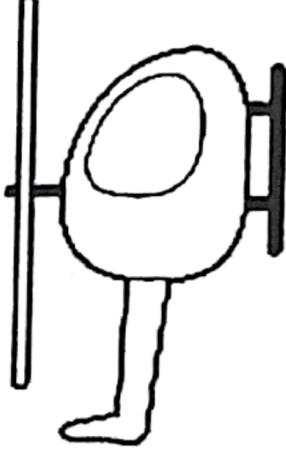
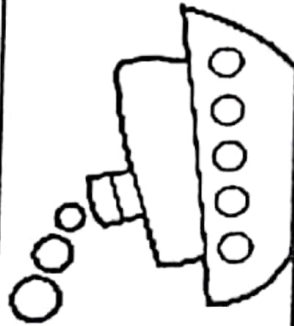
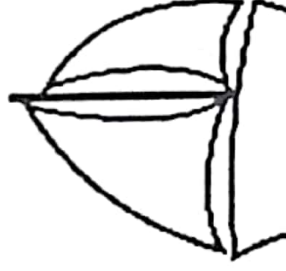
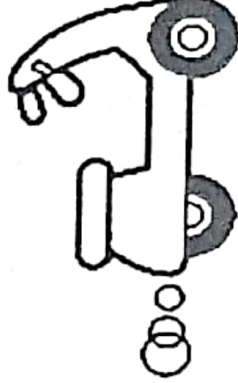
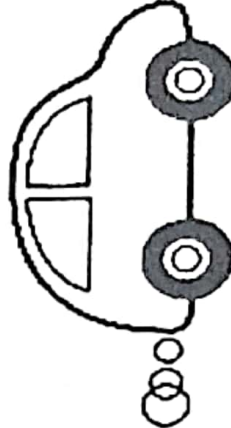
| | | |
|--|---|---|
| <p>POR AIRE</p>  <p>AVIÓN</p>  <p>HELICÓPTERO</p> | <p>POR AGUA</p>  <p>BARCO</p>  <p>VELERO</p> | <p>POR TIERRA</p>  <p>MOTOCICLETA</p>  <p>AUTO</p> |
|--|---|---|

Observa la cantidad de medios de transportes terrestres que encontramos; nombra cada uno de ellos y luego colorea los medios de transportes que tú has usado

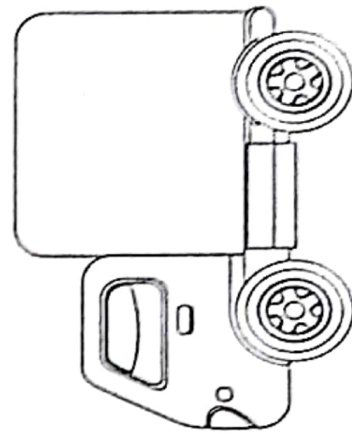
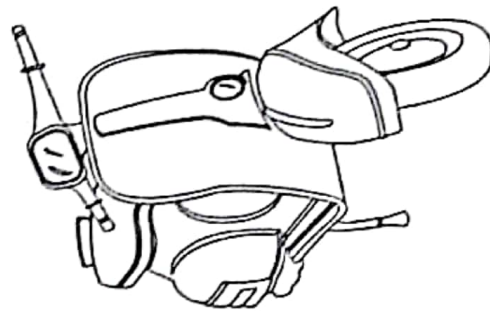
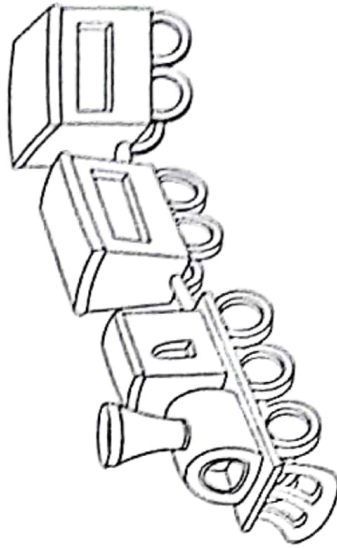
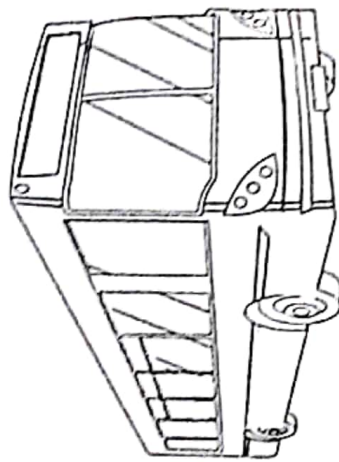
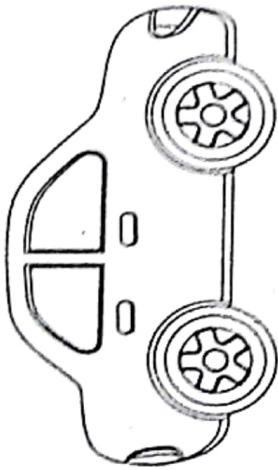

Encierra en un círculo solo el medio de transporte terrestre

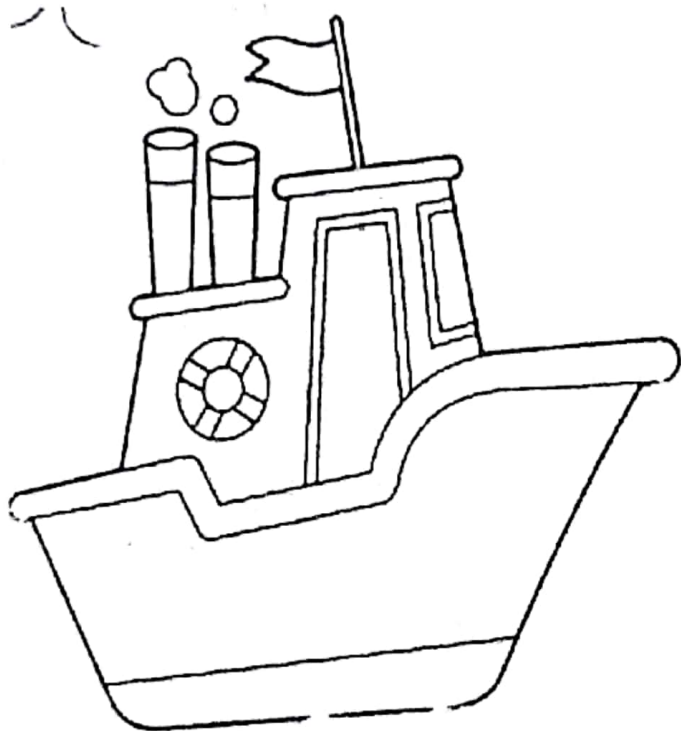

MEDIOS DE TRANSPORTE AEREO

Colorea los medios de transporte.

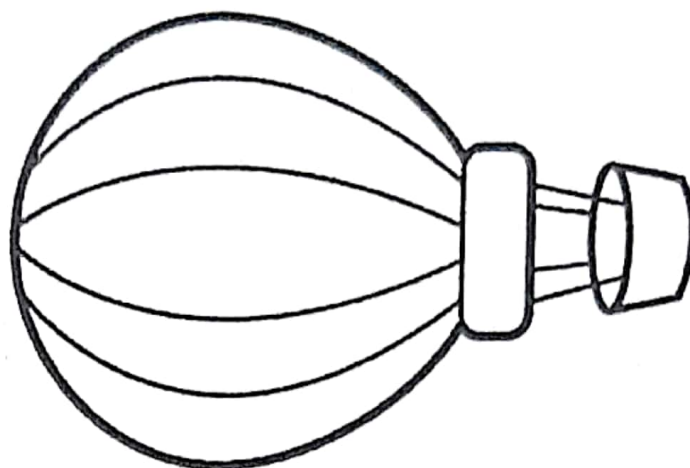
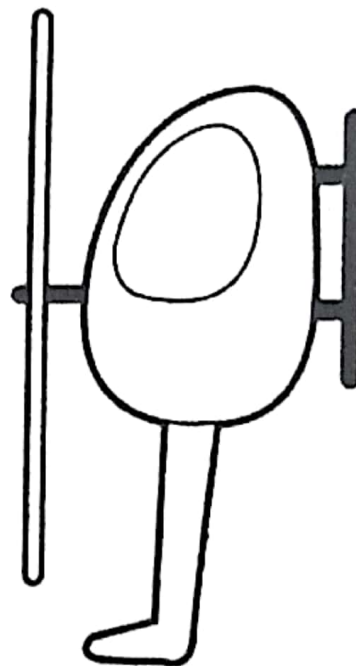
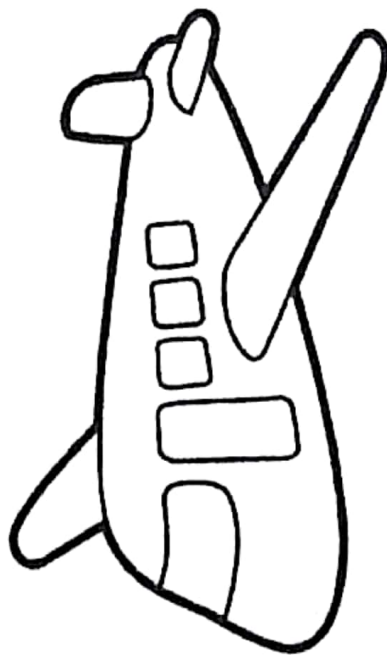

¿Por dónde se desplaza el avión? ¿Puede viajar mucha o poca gente dentro del avión?
Rellena el avión con bolitas de papel. ¡Tú puedes!

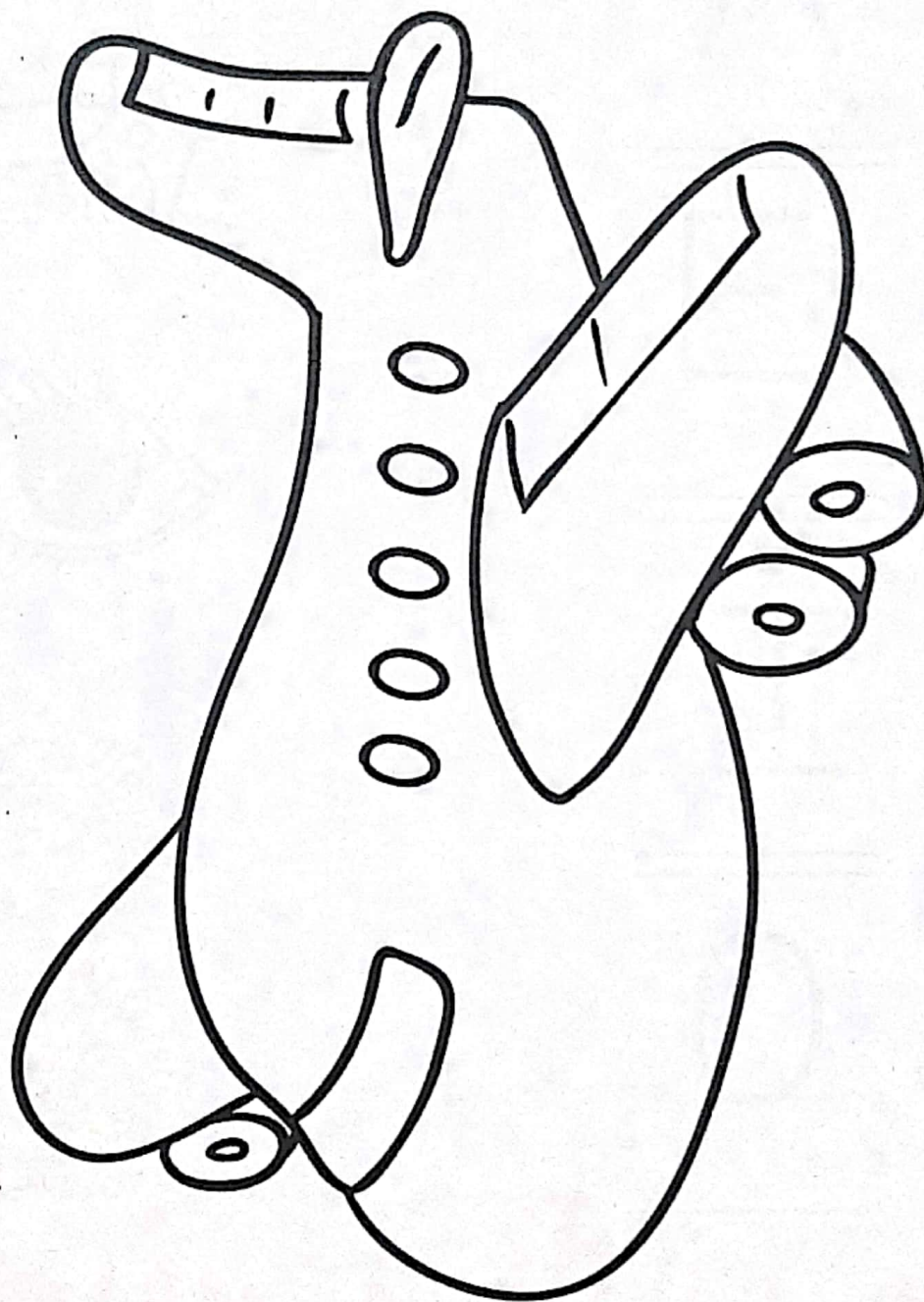

Las Vocales

Observa y nombra cada dibujo, luego une con la vocal correspondiente según sea su nombre

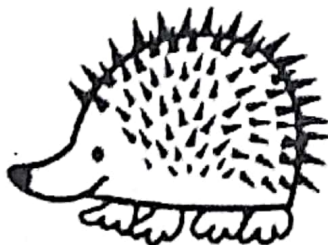
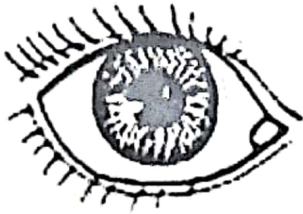

A

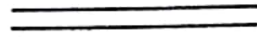

E

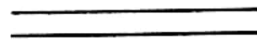

I

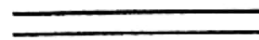

O





Colorea de rojo todas las letras
que encuentre.



A

U

O

E

I

A

A

E

I

U

A

O



Observa y nombra los medios de transportes que se desplazan por el agua.
Colorea el medio de transporte que has utilizado o te gustaría utilizar

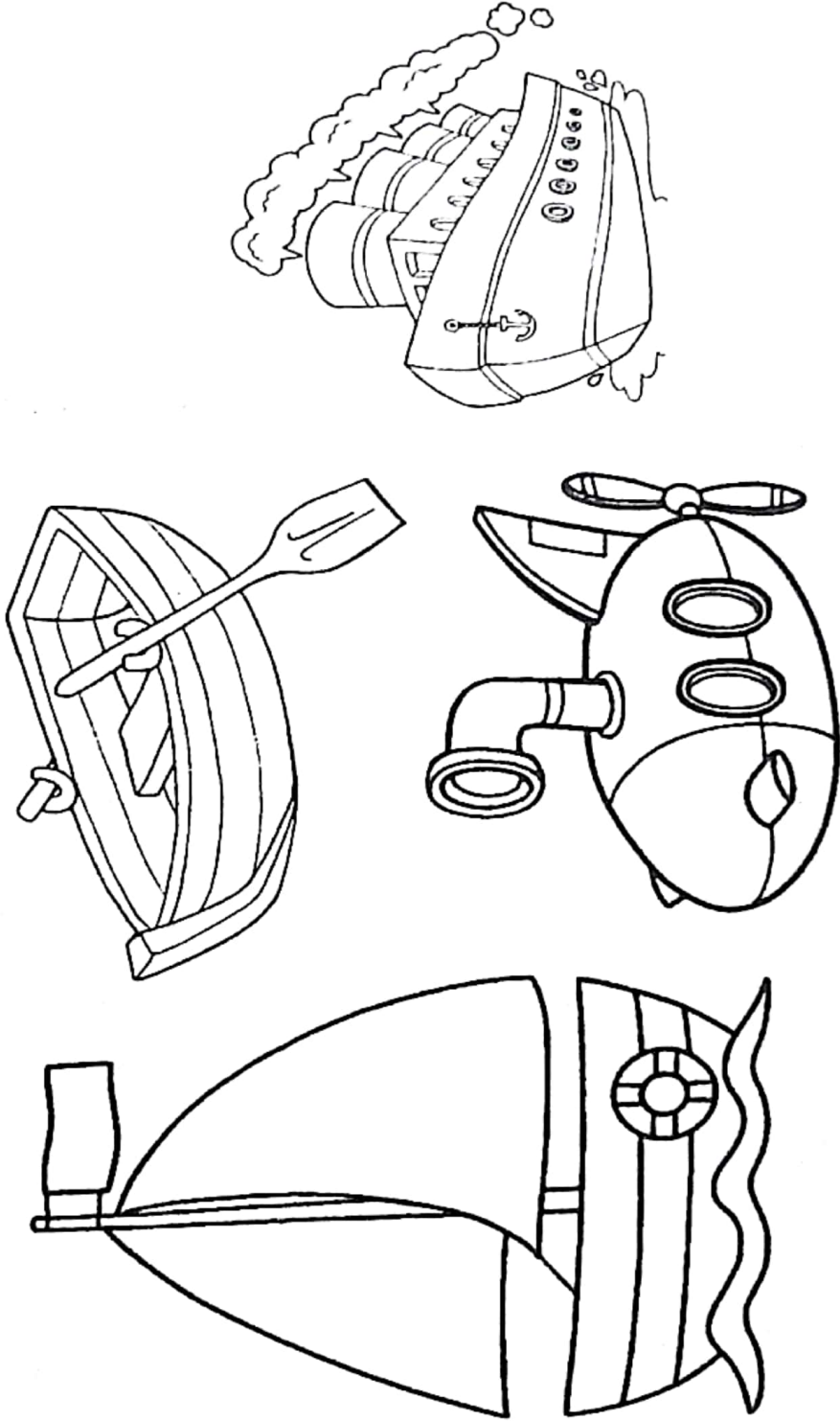

Decora de manera libre el paisaje y pega los barquitos para que puedan navegar
¡Tú puedes!

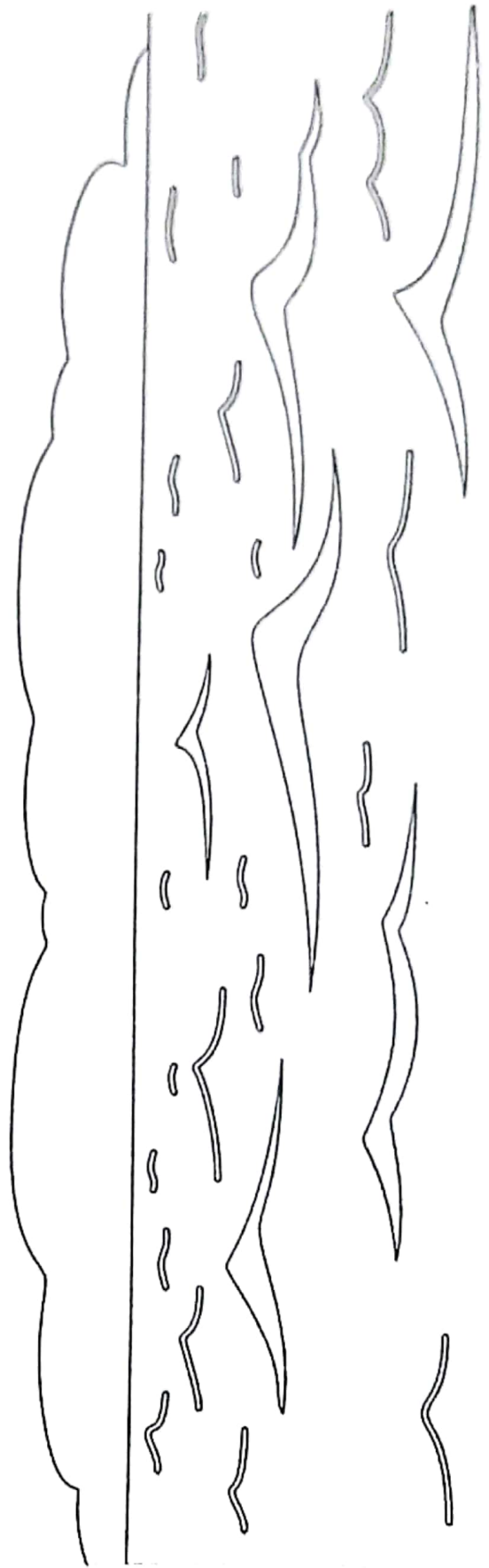

Colorea cada número siguiendo las instrucciones:

Colorea de color rojo el número 1, color verde el 2, amarillo el 3 y de color azul el número 4



Cuenta la cantidad de elementos de cada grupo y une según sea su número. ¡Vamos tú puedes!



3



5

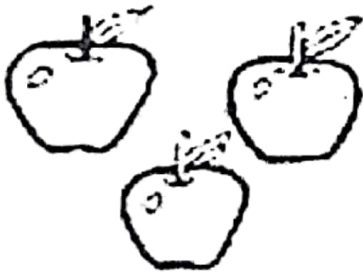

4



1



2

Medios de transporte

Colorea solo los medios de transportes y marca con una X los intrusos

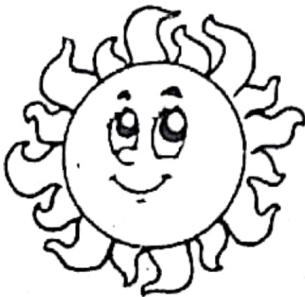
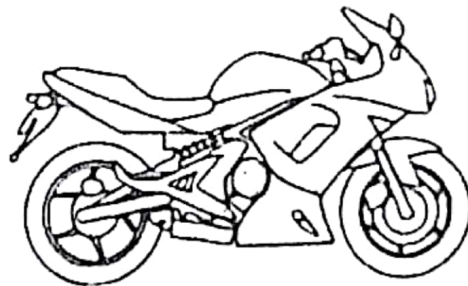
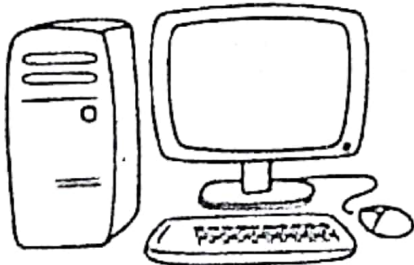
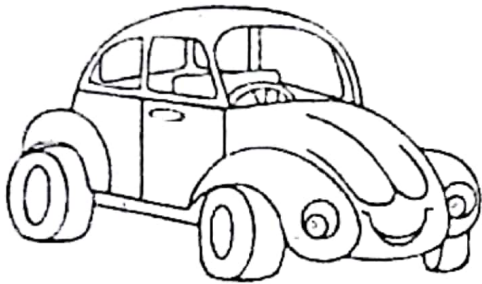

Medios de transporte



Actividad: Colorea los medios de transporte aéreos y marca con una (x) los transportes marítimos.

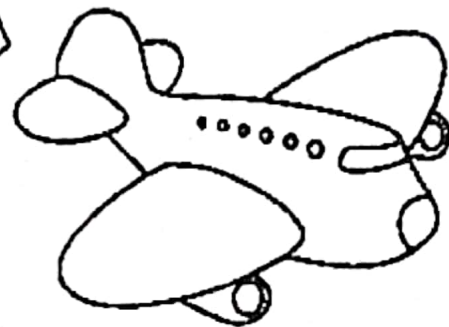
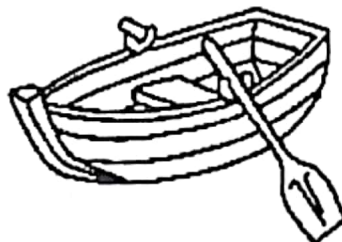
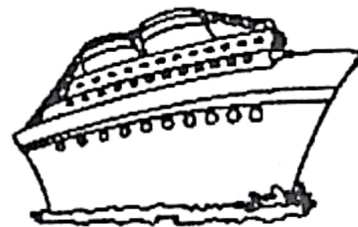

¿por dónde se desplaza el tren? ¿el tren es pequeño o grande?
Decora y colorea de forma libre este lindo tren

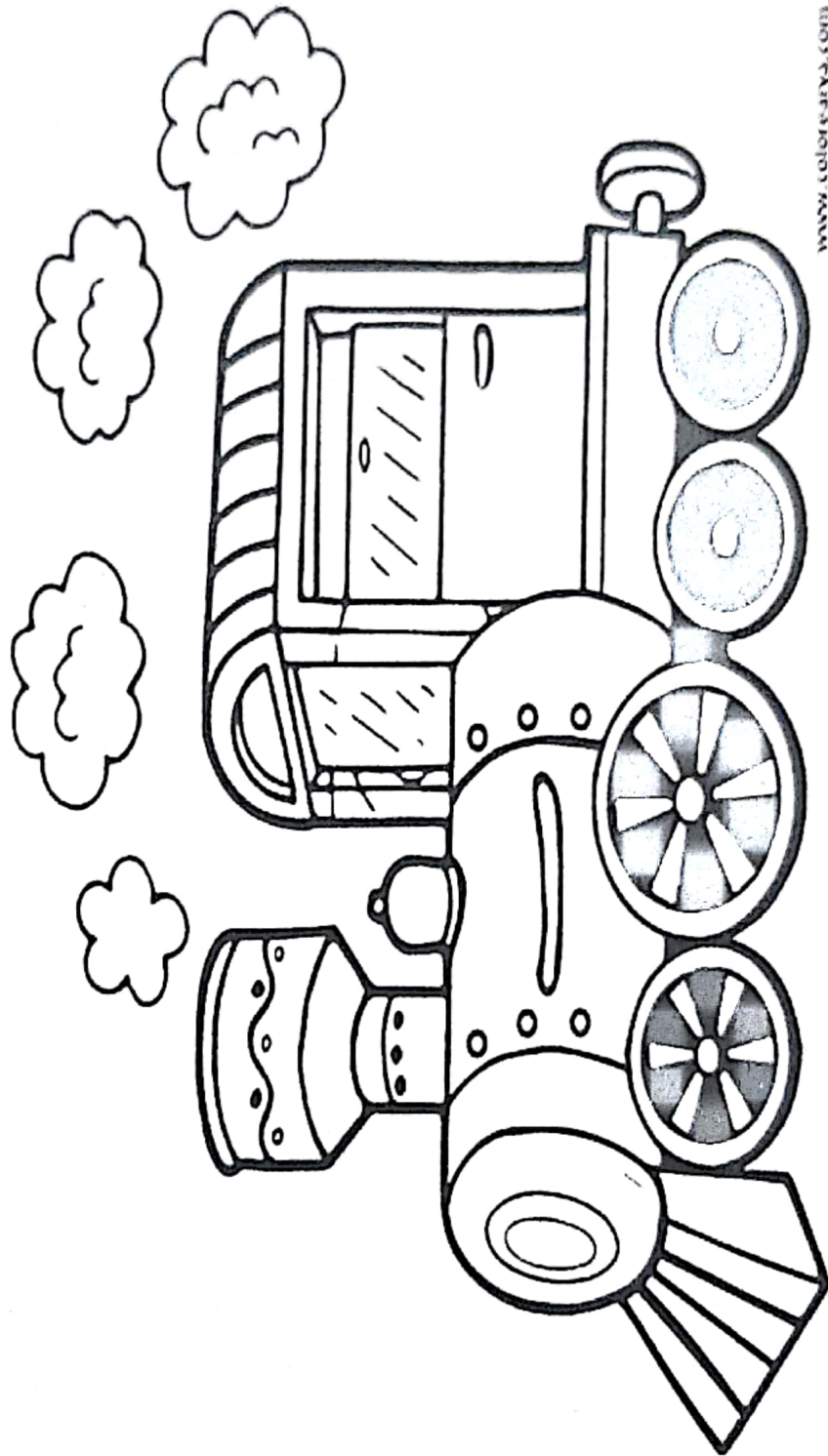

www.colorear.es.com

Une cada medio de transporte con su igual, luego colorea

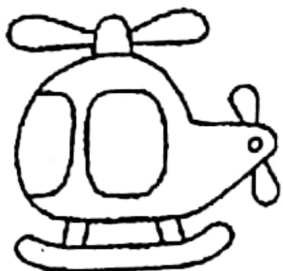

Cuenta los medios de transportes en cada grupo y colorea la respuesta correcta

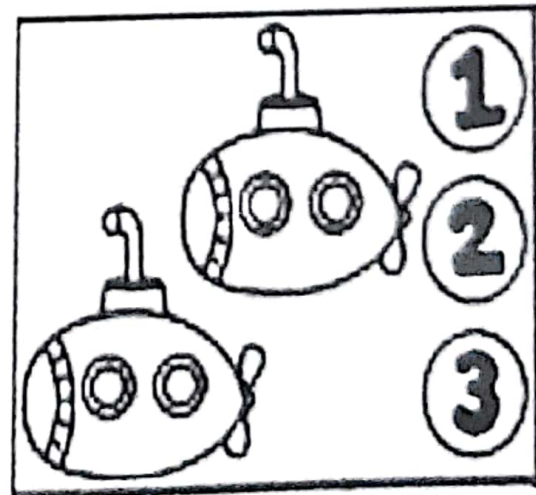
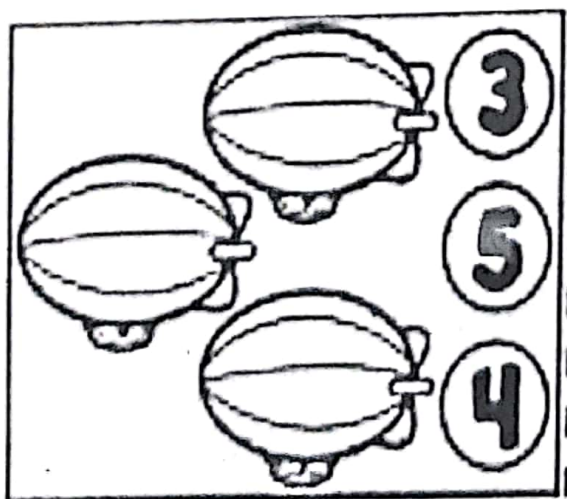
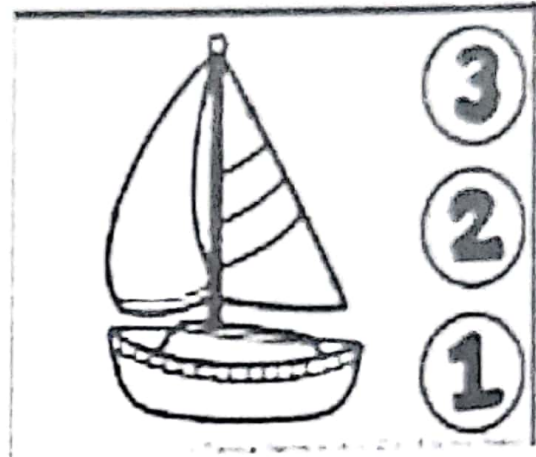
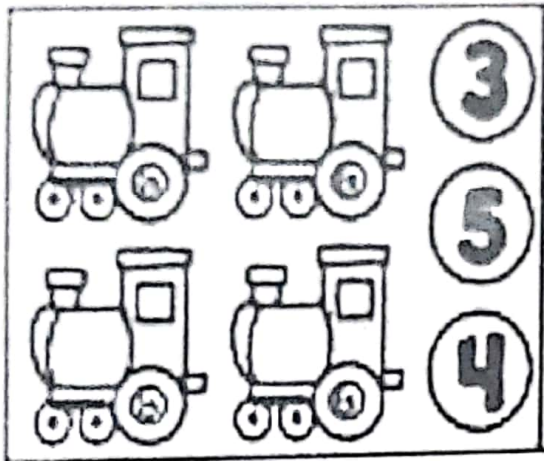

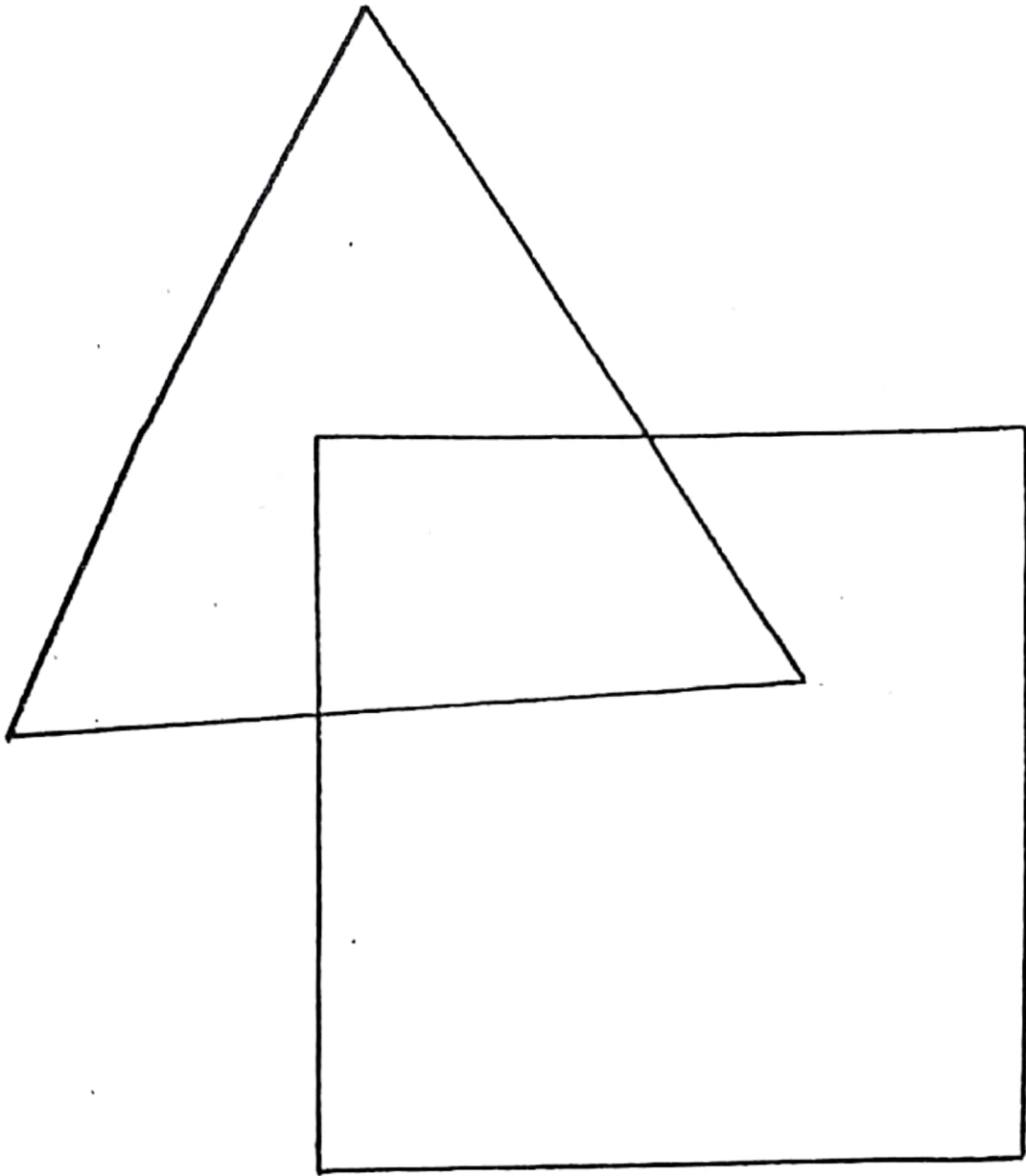

Pinta de color verde el triángulo y de color rojo el cuadrado

Lugares públicos

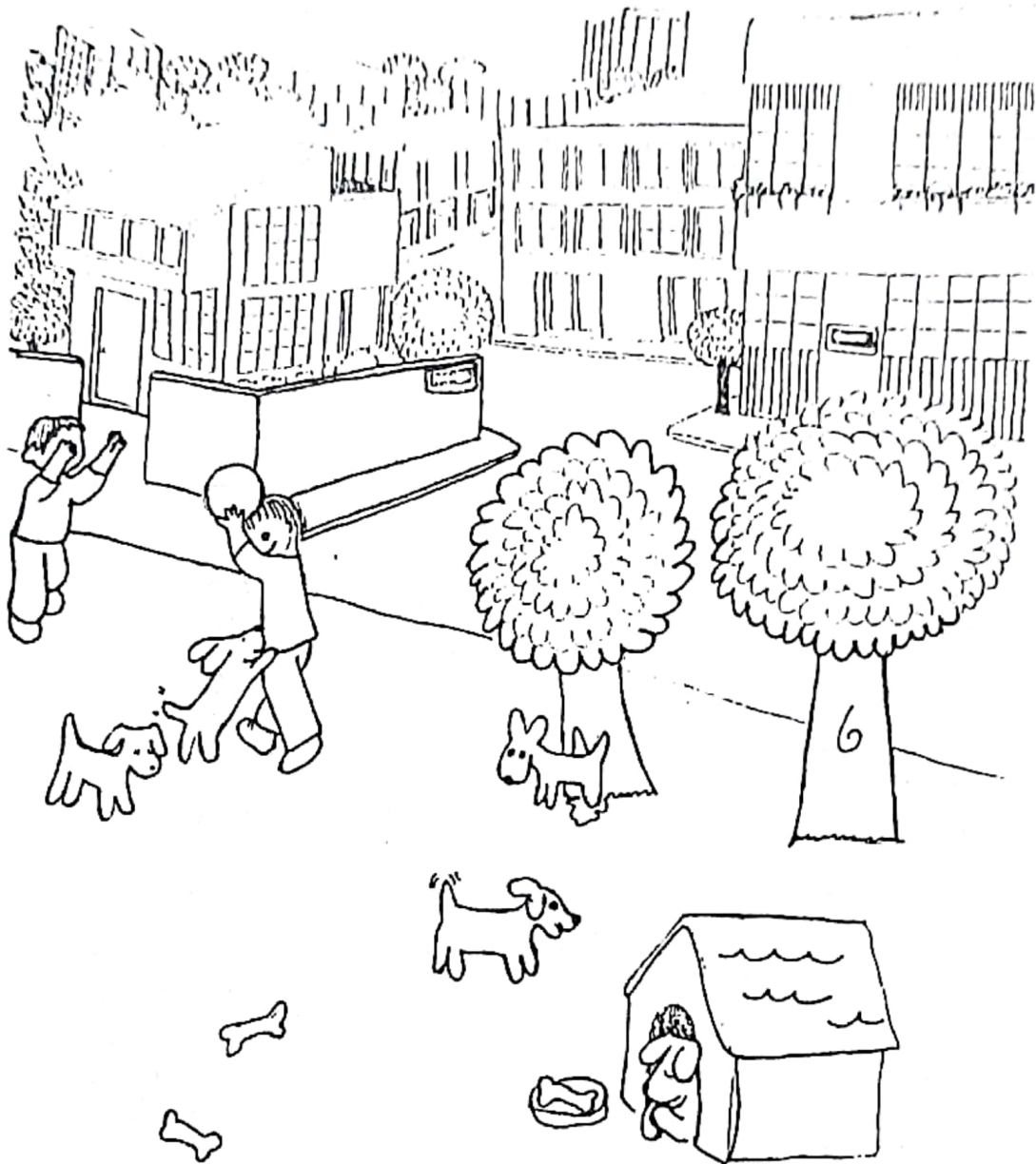

Describe la lámina, luego pinta

Espacios y Lugares Públicos

Son lugares de la ciudad a los cuales tenemos libre acceso. Estos lugares públicos nos sirven para convivir, recrearnos, jugar y comprar. Existen lugares públicos cerrados como bibliotecas, supermercados y otros lugares públicos abiertos como plazas, parques, calles y estaciones

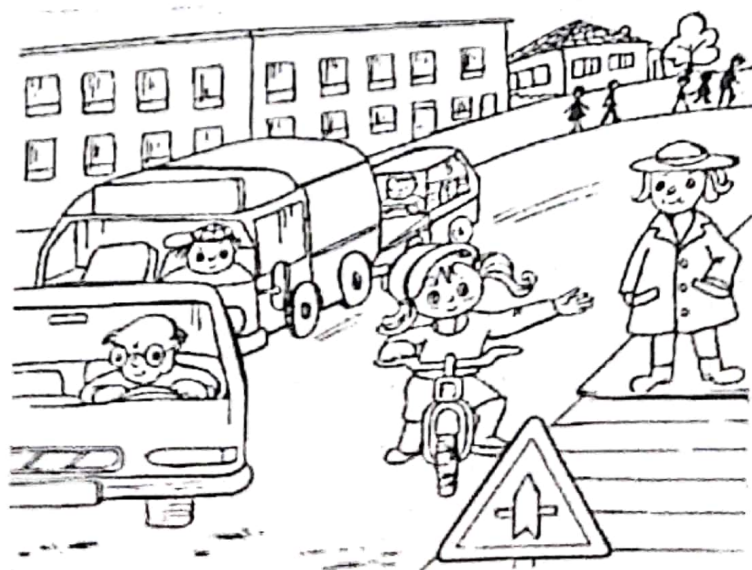
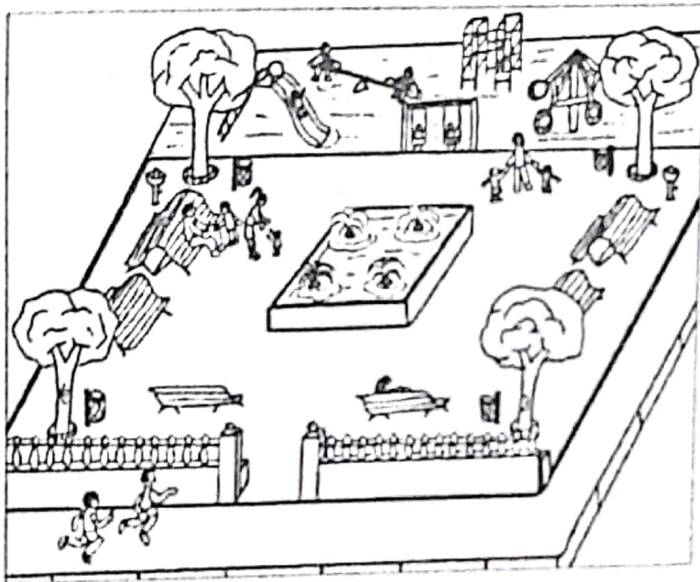

La Plaza

Observa los niños jugando ¿Donde están?

Encierra al niño que tiene una pala en su mano y colorea la niña que se encuentra en el columpio

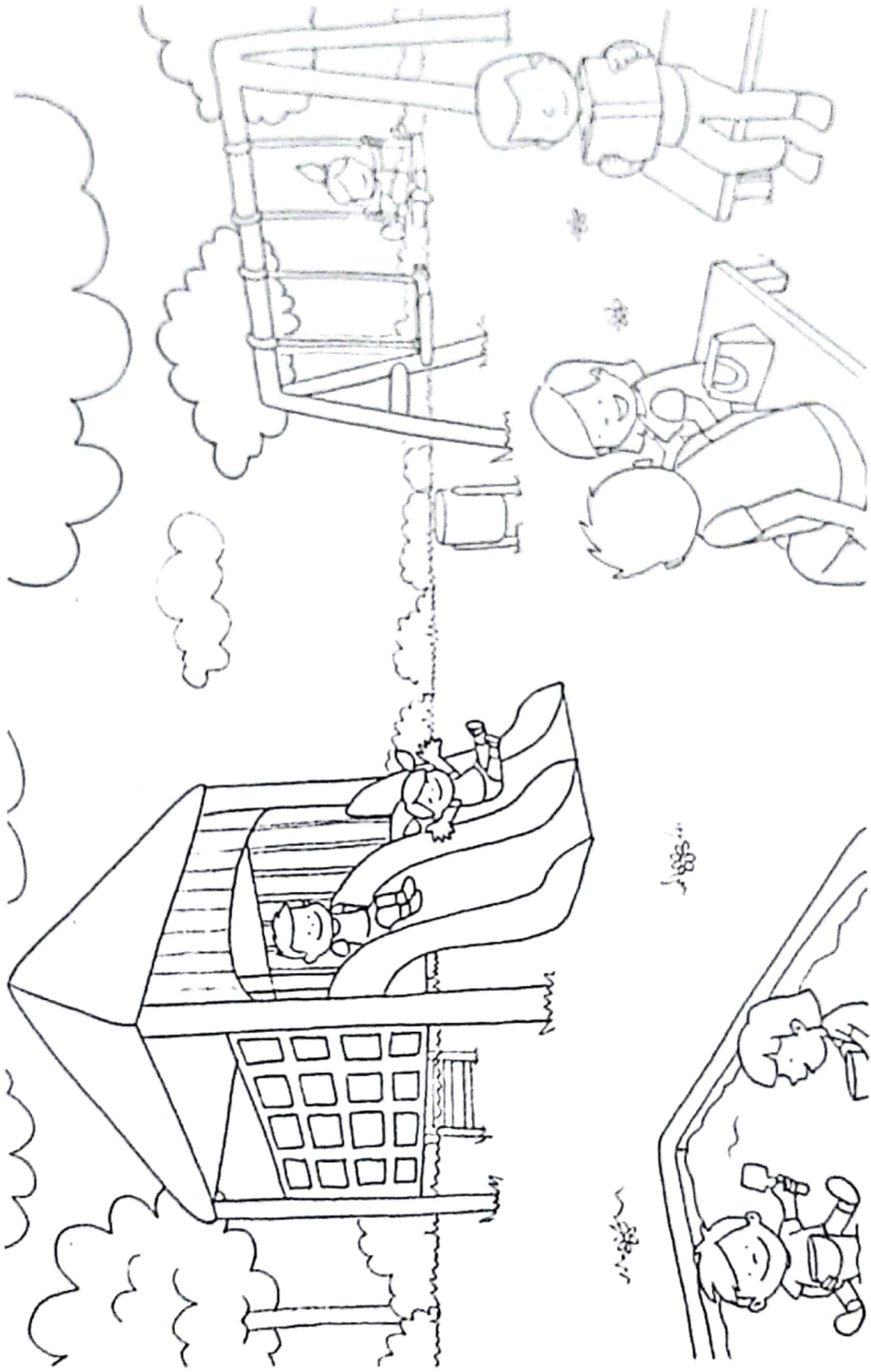

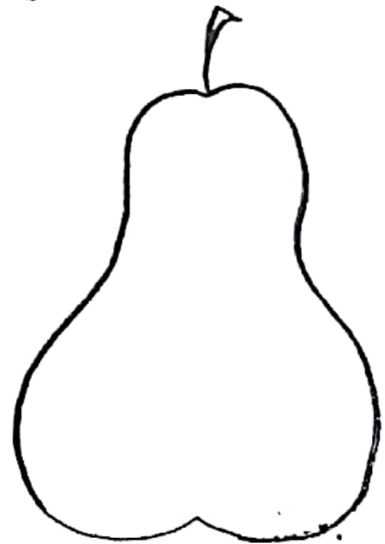
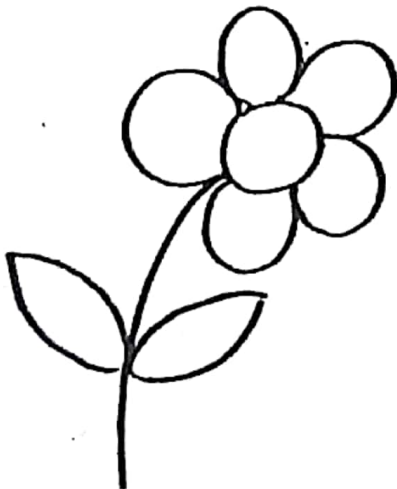
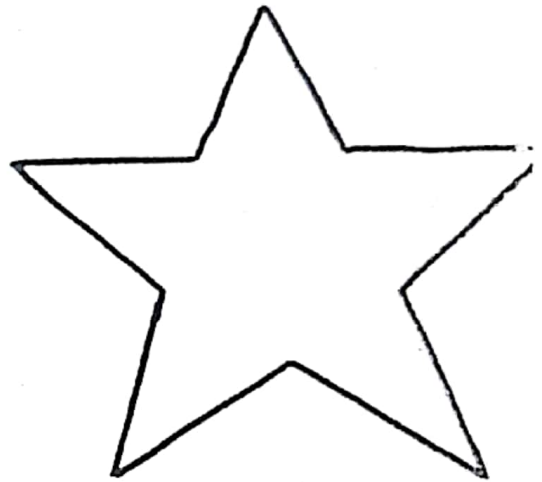
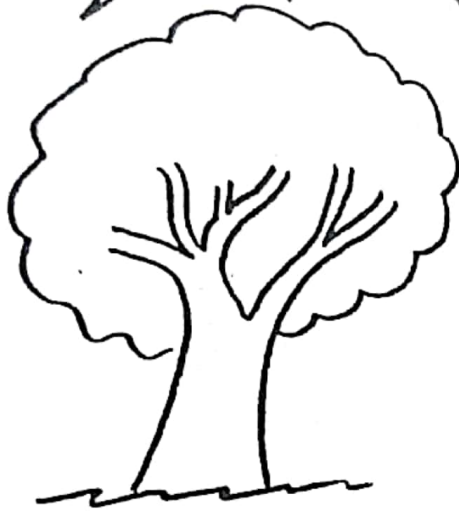
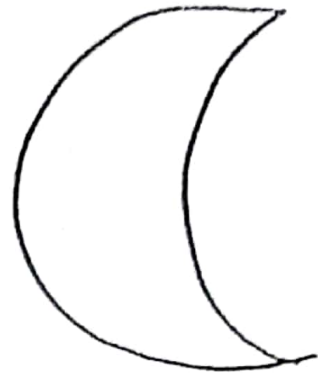
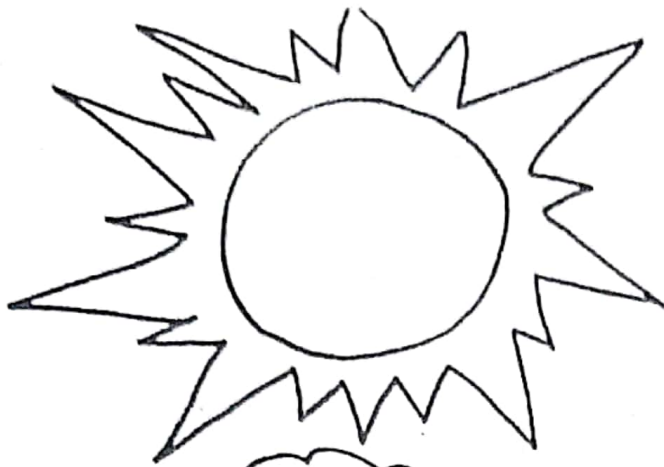

96

Pinta solo los objetos que encontramos en la plaza

La Playa

¿Qué lugar es este? ¿Qué es lo que más te gusta de la playa?
Marca con una X los elementos que no pertenecen a la playa

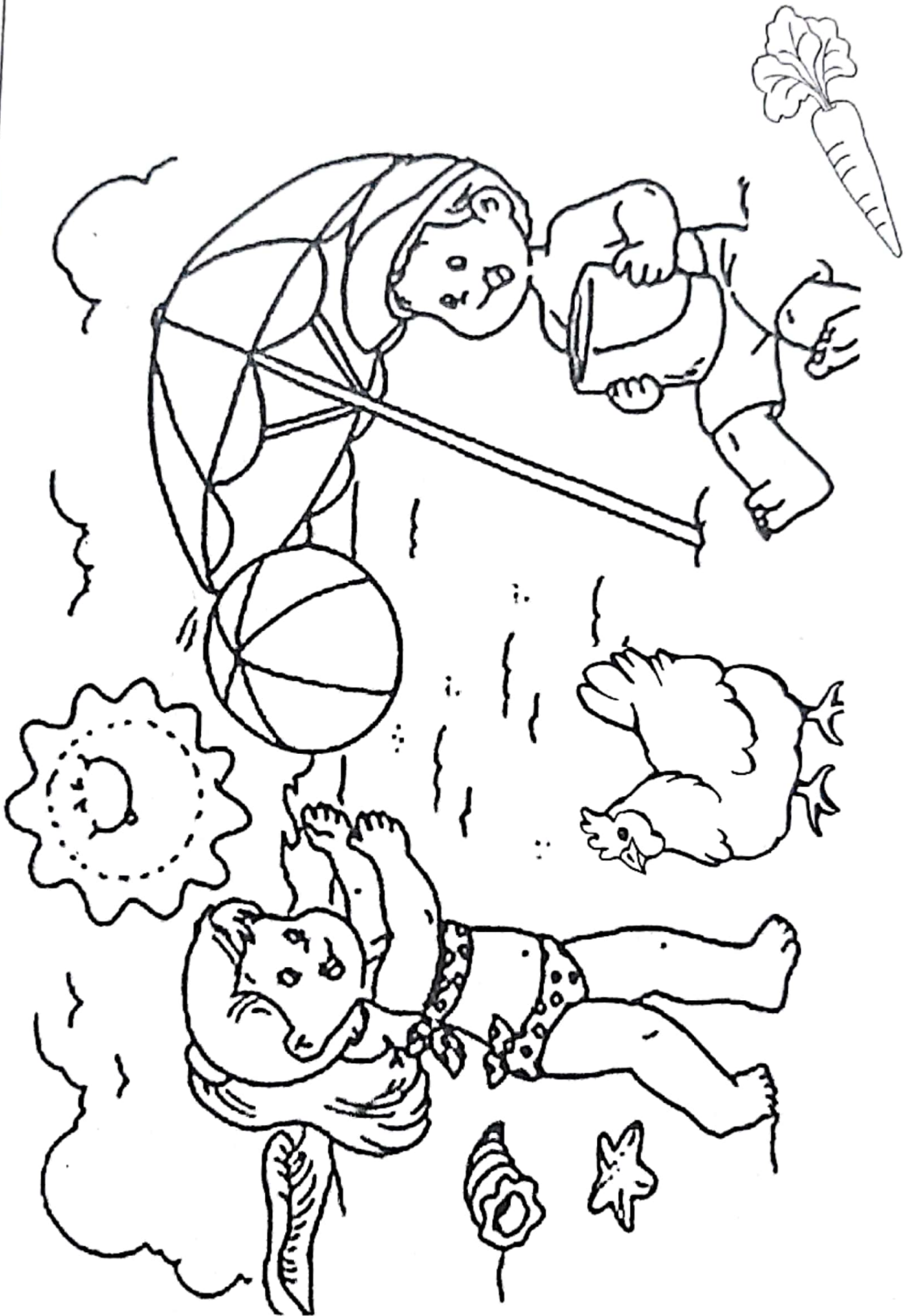

El Supermercado

Colorea a la señora que va con un coche y marca con una cruz al niño



El Circo

Rellena libremente la carpa de circo y luego colorea al payaso

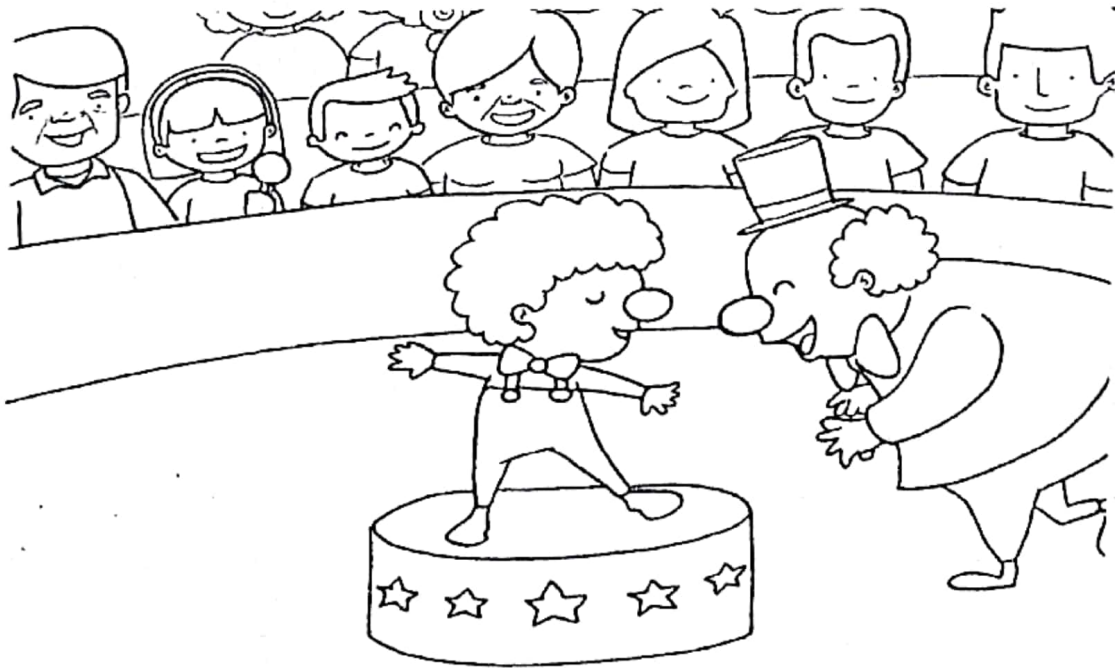
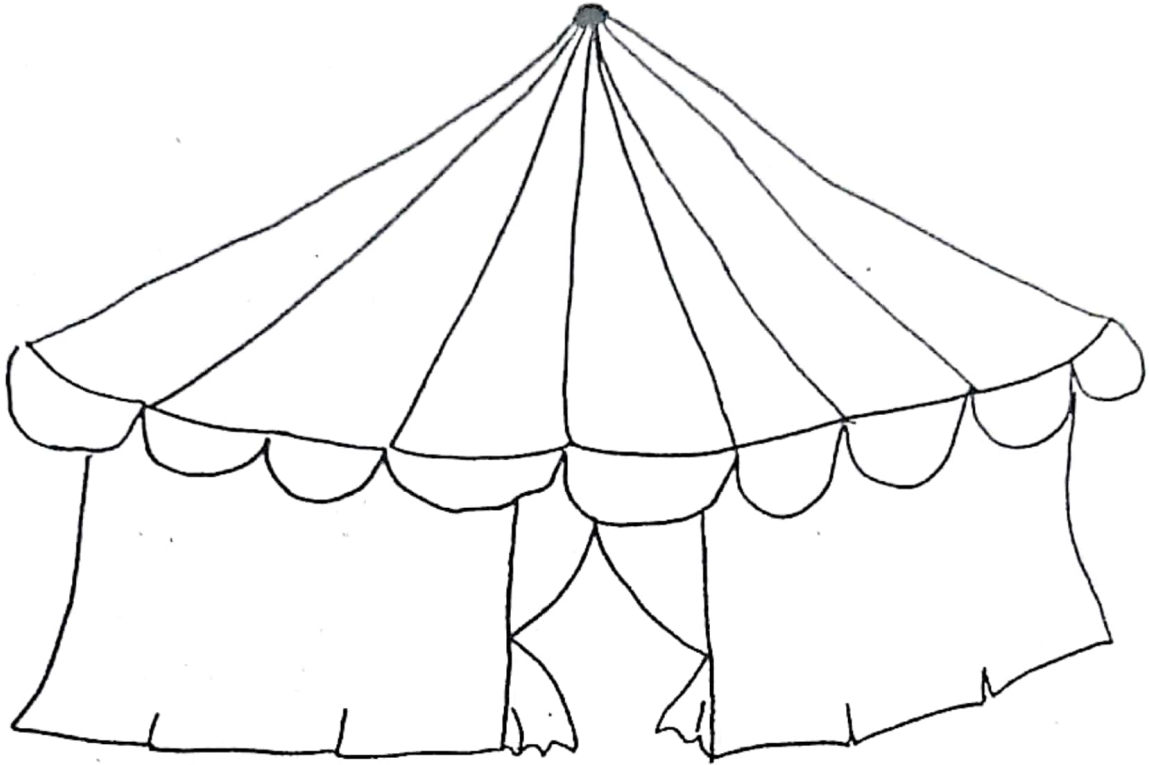



Guía de trabajo fonoaudiológico en casa

Nivel Medio Mayor

Actividades semana 22

1. Objetivo de aprendizaje: Artículos definidos (el-la-los-las)

| | | |
|----------|-----------|---|
| El-----> | Masculino |  |
| La-----> | Femenino |  |

Observa y comenta las imágenes. Une cada una con el artículo que corresponde.

EL - LA



pie

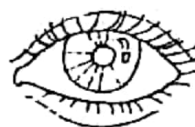

ojo

EL

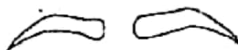

ceja



oreja

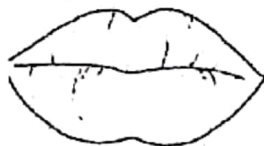

boca

LA



diente

2. Objetivo de aprendizaje: Artículos definidos.

1 - Toca los dibujos y lee las frases. Reptelas varias veces.

2 - Luego usted muestra y le pregunta al niño/a: ¿qué ves aquí? Es importante que conteste utilizando los artículos en plural LOS - LAS, según corresponda.

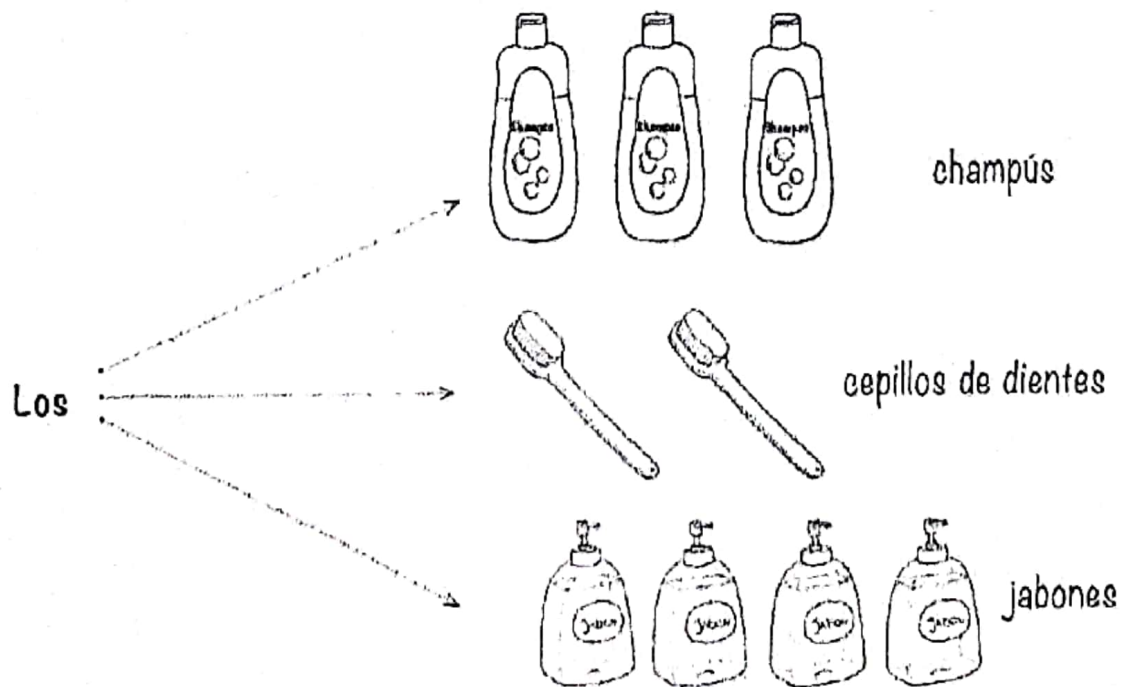
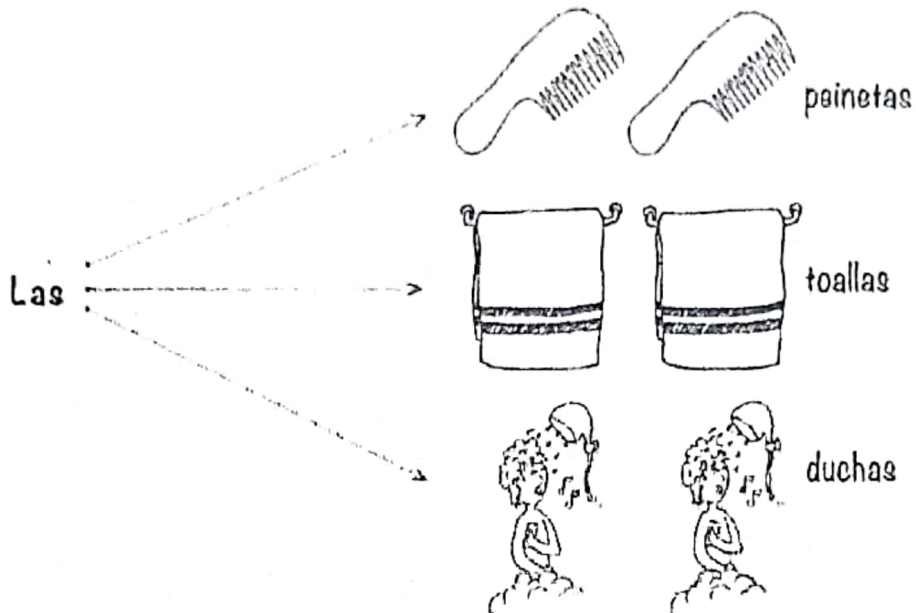

Actividades semana 23

1. Objetivo de aprendizaje: Artículos Indefinidos (un-unos-una-unas)

Observa y comenta las imágenes. Une cada una con el artículo que corresponde.

UN - UNA



regla

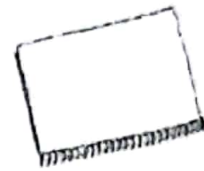

cuaderno



libro



pincel

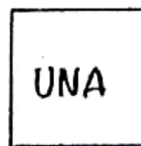

témpera



plumón

2. Objetivo de aprendizaje: Artículos Indefinidos (un-unos-una-unas)

1 - Toca los dibujos y lee las frases. Repítelas varias veces.

2 - Luego usted muestra y le pregunta al niño/a: ¿qué ves aquí? Es importante que conteste utilizando los artículos UNOS - UNAS, según corresponda.

UNAS

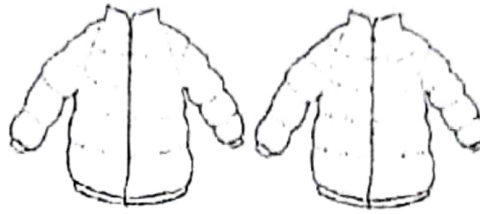

parkas

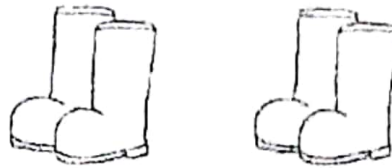

botas



poleras



zapatos

UNOS

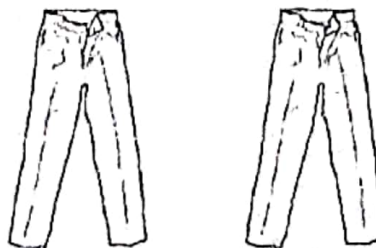

pantalones



gorros

Actividades semana 24

1. Objetivo de aprendizaje: Pronombres demostrativos

Observa y comenta las imágenes. Une cada una con el pronombre que corresponde.

ESTE - ESTA

florero



ESTE

mecedora



lámpara

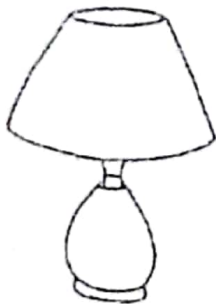

sillón

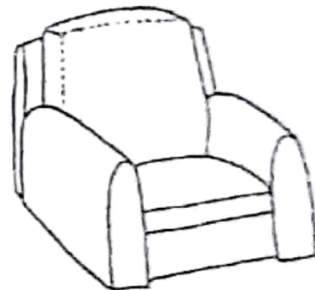

ESTA

mesa

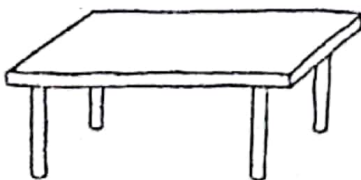

cojín

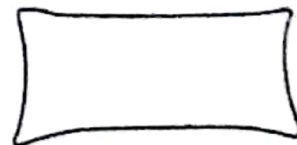

2. Objetivo de aprendizaje: Pronombres demostrativos.

ESTOS - ESTAS, según corresponda. Escriba las respuestas que de el niño/a.

Estos gorilas están saltando.
¿Quiénes están saltando?

.....

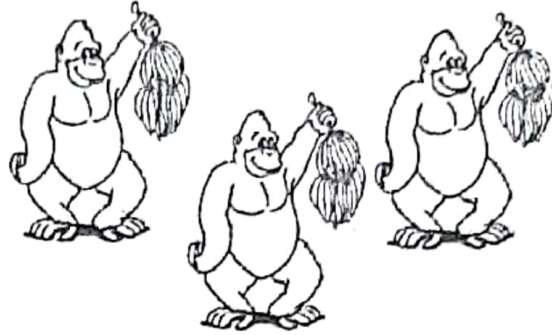

Estos leones son grandes.
¿Quiénes son grandes?

.....

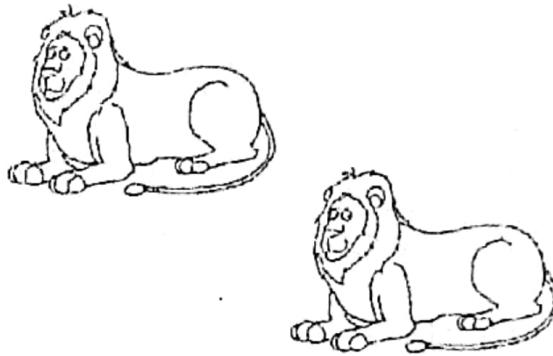

Estas cebras son rayadas.
¿Quiénes son rayadas?

.....

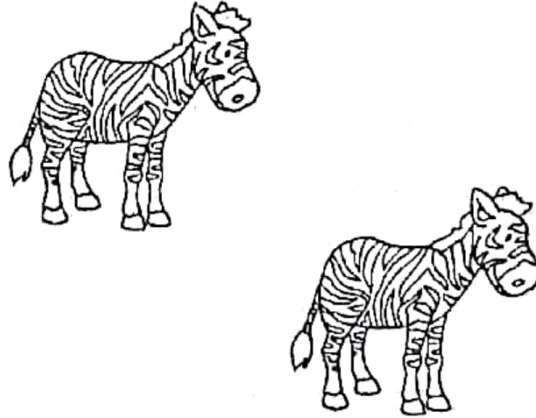

Estos jabalíes son de color café.
¿Quiénes son de color café?

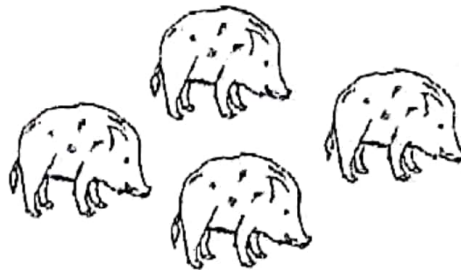

.....







Actividades semana 25

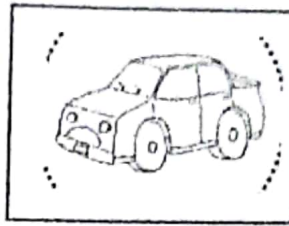

1. Objetivo de aprendizaje: Preposiciones

Nuestra amiga Sofía quiere ir a muchos lugares y con muchas personas. Ayúdala completando los recuadros con los lugares, personas o transporte que necesite para viajar. Cuando logres una oración, repítela poniendo énfasis en las preposiciones A- EN- CON. Colorea

 Va a  en 

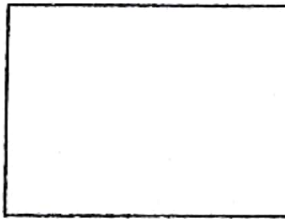
 Va a  con 

 Va a  en 

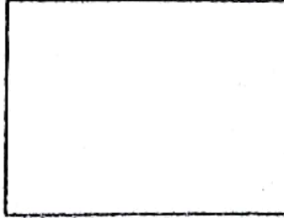
 Va a  con 

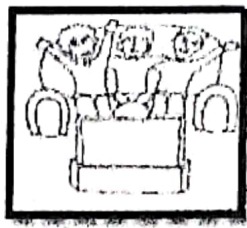
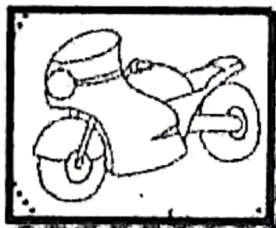

2. Objetivo de aprendizaje: Preposiciones

Arma y repite varias veces las oraciones.

¡Fíjese que utilice la preposición CON!

¿Con quién fue Felipe a la playa?



Felipe fue a la playa con.

